

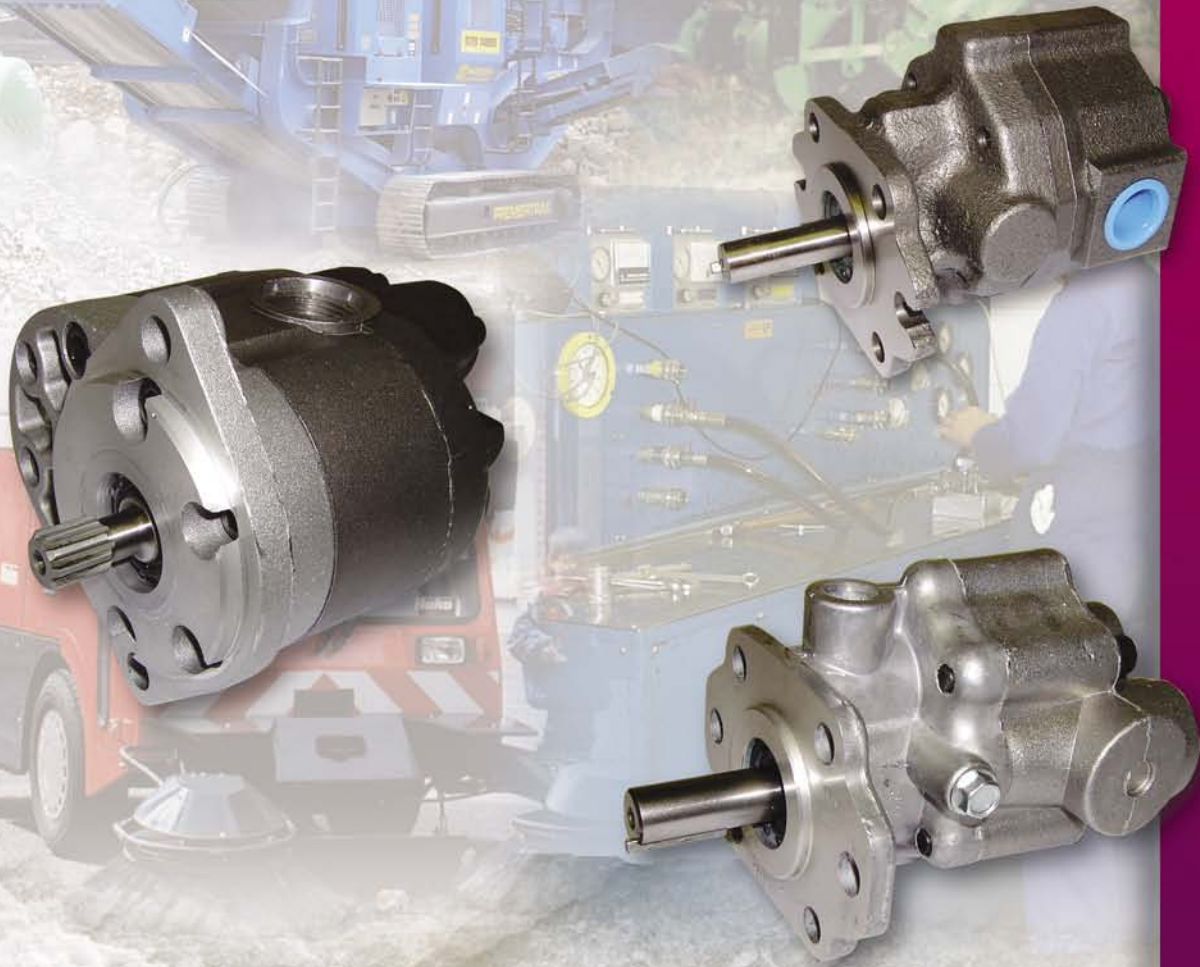

WEBTEC

WEBTEC PRODUCTS LIMITED





Hydraulic Pumps



**Quality Hydraulic Components
from the Webtec Range**

Hydraulic Pumps

CONTENTS

	DESCRIPTION	PAGE No.
	B Series Gear Pumps, 1 to 10 cc/rev Capacity	1
	YB Series Gear Pump, 2.5 to 12 cc/rev Capacity	9
	HCS Series Gear Pumps, 12 to 32 cc/rev Capacity	13
	YC Series Gear Pumps, 12 to 32 cc/rev Capacity	15

B Series

Gear Pumps 1 to 10 cc/rev Capacity

An **EXTERNAL GEAR PUMP** consists basically of a drive gear (rotated by an external source via a shaft) and a meshing driven gear in a housing with an inlet and outlet port. Fluid is forced through the pump as it becomes trapped between the rotating gear teeth and the housing. Because the output per revolution is based on the fixed volume displaced by the gears, the flow rate may be varied only by varying the gear speed.

Symbol

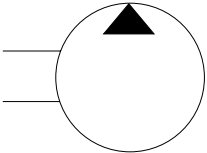

Features

- Customer can select from 10 standard displacements ranging from 1 - 10 cc/rev with pressure to 241 bar and speeds to 3500 rpm.
- Durable construction consisting of heat treated alloy steel shafts and gears, high density grey iron body construction.
- Double lip seals and heavy duty needle bearings fitted as standard features.
- Straight keyed shafts are standard with tang shafts available as an option.
- Mechanical, high pressure or viton seals available as an option.
- Relief and outlet check valves available as an option.
- Suitable for mining and underground use.

Quality Hydraulic Components from the Webtec Range

B Series

Pumps

Typical Code

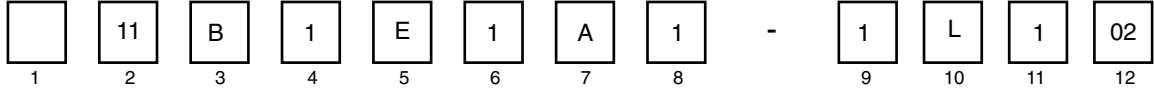

1 Application

No letter indicates pump

2 Displacement Code

Actual Displacement

Code	In ³ /rev (cc/rev)	Gear Width in (mm)
06	.06 (.980)	.18 (4.57)
11	.11 (1.80)	.31 (7.87)
15	.15 (2.46)	.25 (6.35)
22	.22 (3.60)	.37 (9.40)
30	.30 (4.91)	.50 (12.70)
37	.37 (6.06)	.62 (15.75)
47	.47 (7.70)	.80 (20.32)
59	.59 (9.66)	1.00 (25.4)

3 B Series Pump

4 Type of Control

1 Fixed Clearance

5 Mounting

E 4 Bolt (1.781 dia, Pilot)
F 2 Bolt (2.000 dia, Pilot)

6 Porting

- 1 1/2" NPTF Side Inlet (Cover) & 3/8" NPTF Side Outlet (Body)
- 2 1/2" NPTF Side Inlet and Outlet (Both Cover)

7 Shaft Extension

- A Tang (.50 dia. x .147 wide x .312 Extension)
- B .50 dia Straight Shaft with .12 Sq Key, 1.50 Extension

8 Valving

- X No Valves
- 1 Relief only
- 2 Relief and Outlet Check

9 Customer Variation

- Standard (Buna-N Seal)
- 1 Outboard Bearing
- 2 Mechanical Seal (300 psi)
- 3 High Pressure Seal (100 psi)

10 Shaft Rotation (Viewed from Shaft End)

- R Clockwise
- L Counter-Clockwise

11 Design Modification

12 Relief Valve Setting

On all pumps incorporating relief valves, pump code must indicate relief valve pressure setting which is to be indicated as follows: 01 = 100, 02 = 200 etc. These digits represent desired valve setting multiplied by 1/100. When no specific valve setting is specified by customer relief will be set at 06B thru 30B @ 2000 psi, 37B & 47B @ 1200 psi and 59B @ 750 psi.

Use these squares to pencil in your coding requirements

<input type="text"/>	<input type="text"/>	<input type="text"/>	<input type="text"/>	<input type="text"/>	<input type="text"/>	<input type="text"/>	<input type="text"/>	<input type="text"/>	<input type="text"/>	<input type="text"/>	<input type="text"/>
1	2	3	4	5	6	7	8	9	10	11	12
<input type="text"/>	<input type="text"/>	<input type="text"/>	<input type="text"/>	<input type="text"/>	<input type="text"/>	<input type="text"/>	<input type="text"/>	<input type="text"/>	<input type="text"/>	<input type="text"/>	<input type="text"/>
1	2	3	4	5	6	7	8	9	10	11	12

Quality Hydraulic Components from the Webtec Range

Specifications

Max. Pressure:
241 bar

Capacity:
0.98 to 9.66 cc/rev

Max Speed:
3500 rpm

Porting:
1/2" NPTF Inlet (Cover) 3/8"
NPTF Side Outlet (Body)
1/2" NPTF Inlet and Outlet
(Both Cover)

Mounting:
Universal mounting flange permits either 4 bolt
or 2 bolt AA with optional adaptor Ring

Shafts:
Straight key shafts standard Tang shafts
optional

Seals:

Double lip, temperature and oil resistant standard

Optional at extra cost; viton mechanical and double lip high pressure.

Maximum back pressure all seals 0.7 bar, except for mechanical 21 bar, and high pressure which is 7 bar

Relief Valve:

Standard models with integral Relief valves will be set as follows

06B to 30B @ 2000 psi - Code 20

37B to 47B @ 1200 psi - Code 12

59B @ 750 psi - Code 7.5

Model	A	B
06B	3.32" (84.33mm)	2.69" (68.33mm)
11B	3.45" (87.63mm)	2.82" (71.63mm)
15B	3.39" (86.11mm)	2.76" (70.10mm)
22B	3.51" (89.15mm)	2.88" (73.15mm)
30B	3.64" (92.46mm)	3.01" (76.45mm)
37B	3.76" (95.50mm)	3.13" (79.50mm)
47B	3.94" (100.08mm)	3.31" (84.07mm)
59B	4.14" (105.16mm)	3.51" (89.15mm)

Installation Details

Dimensions in millimetres

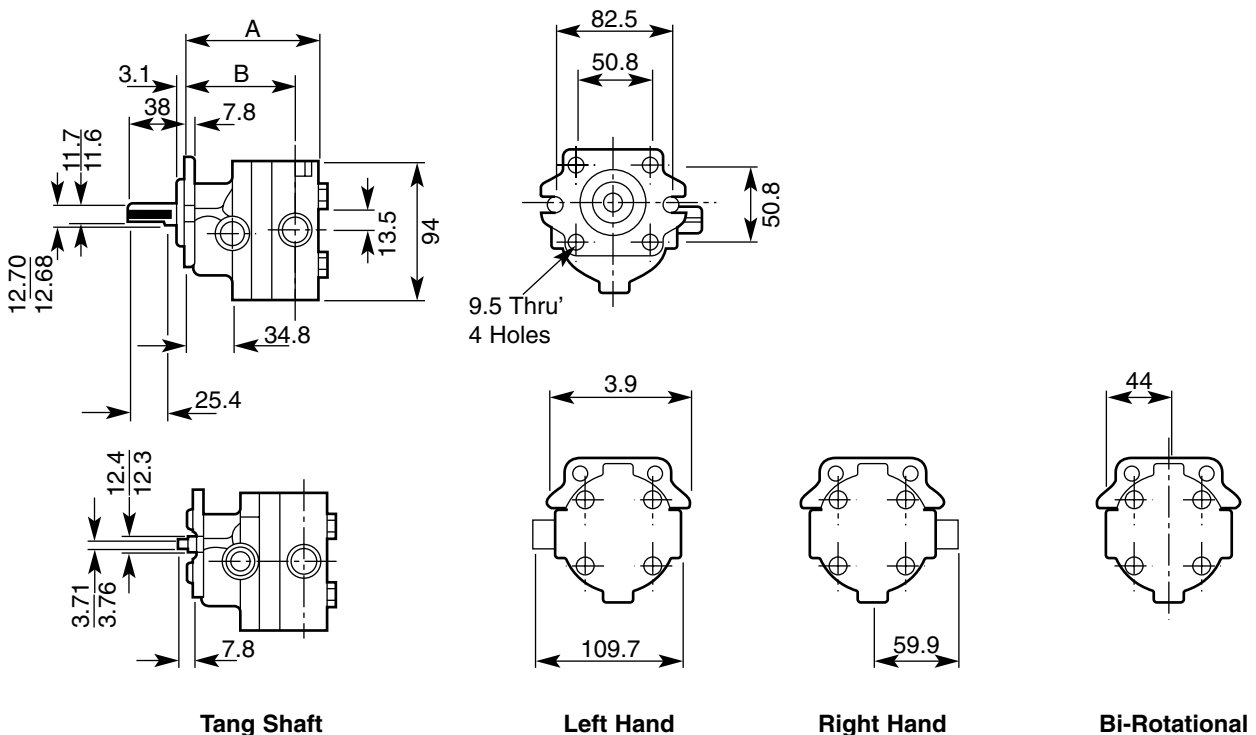

Quality Hydraulic Components from the Webtec Range

Typical Performance Curves

'B' Series Pumps

Note: These curves depict maximum working pressures. Pressures shown in order code are full-flow relief set pressures.

130 SSU Hydraulic Oil @ 120°F

06B1 - R or L

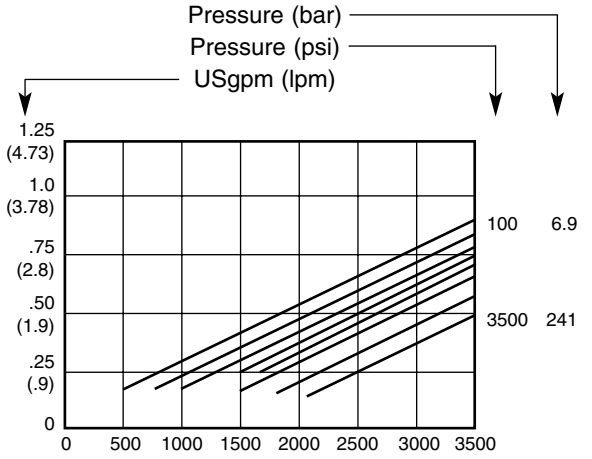
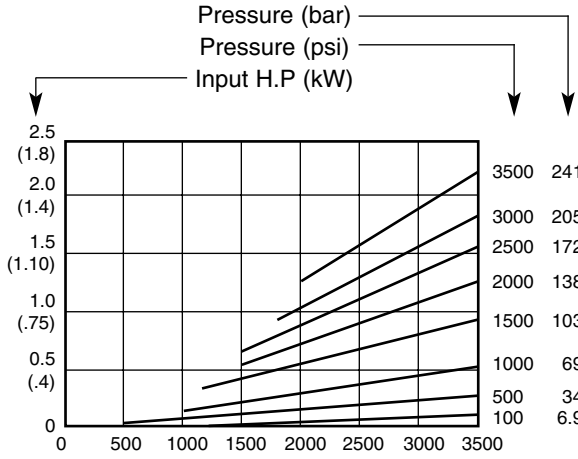

11B1 - R or L

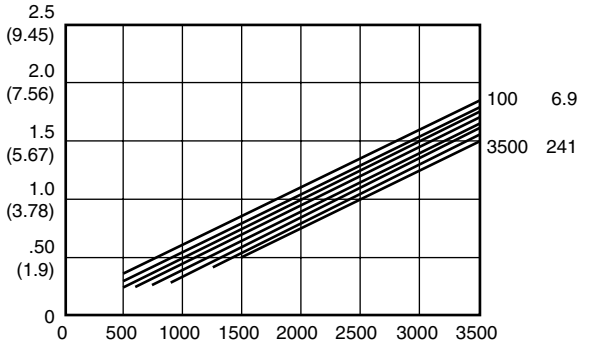
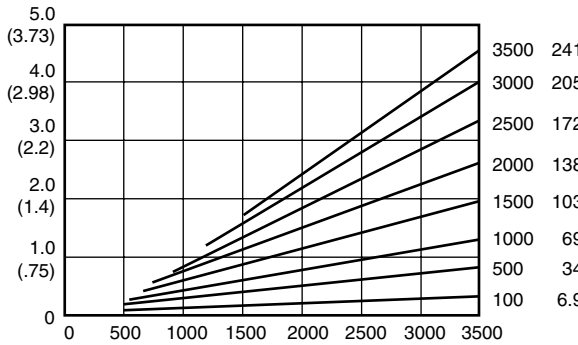

15B1 - R or L

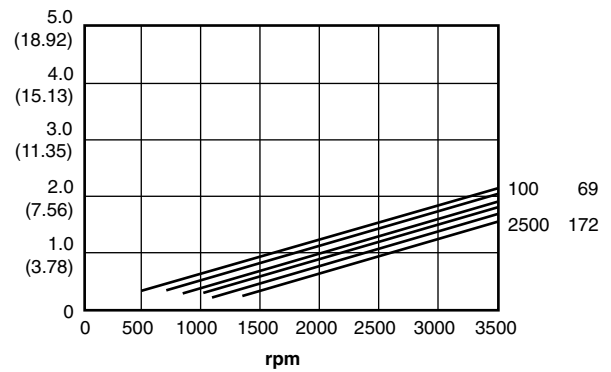
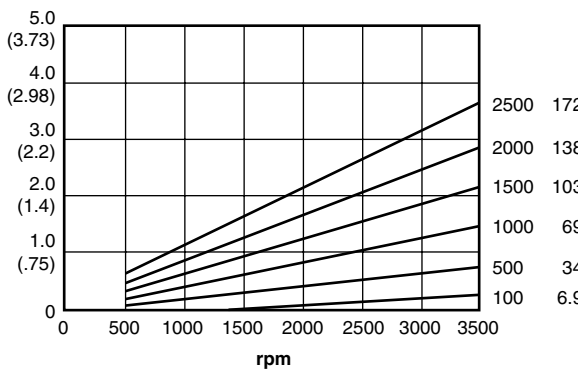

Quality Hydraulic Components from the Webtec Range

Typical Performance Curves

'B' Series Pumps

Note: These curves depict maximum working pressures. Pressures shown in order code are full-flow relief set pressures.

130 SSU Hydraulic Oil @ 120°F

22B1 - R or L

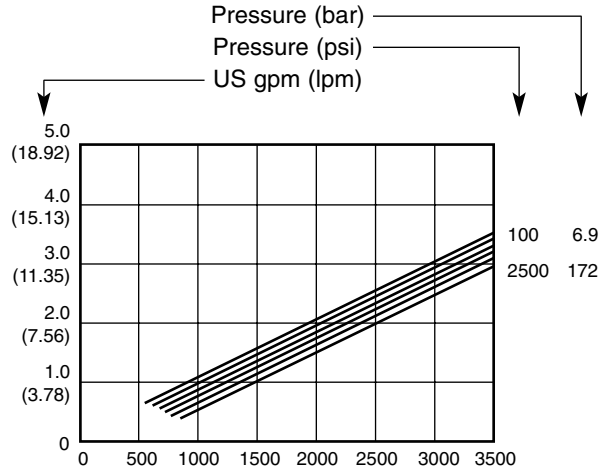
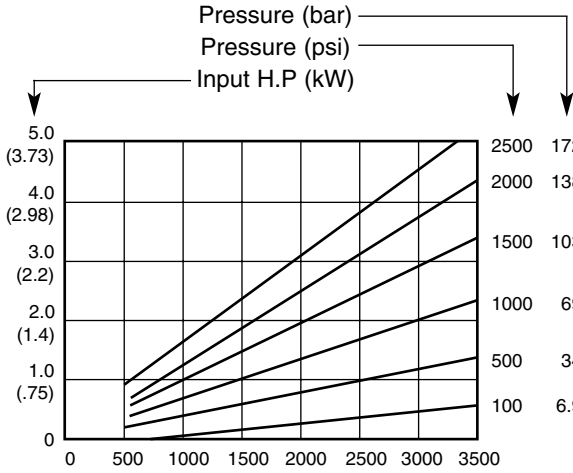

30B1 - R or L

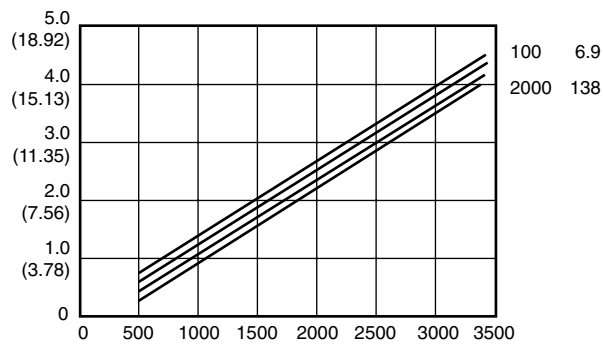
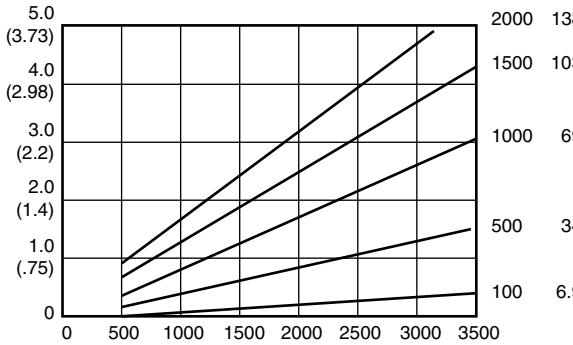

37B1 - R or L

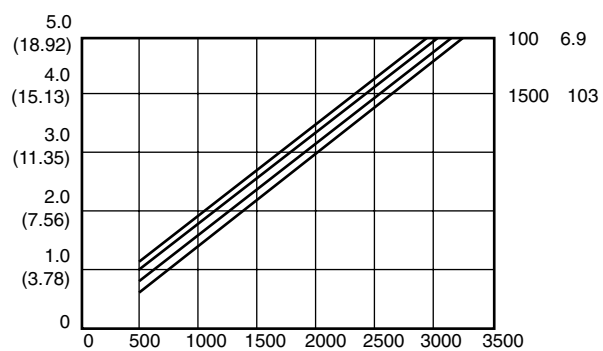
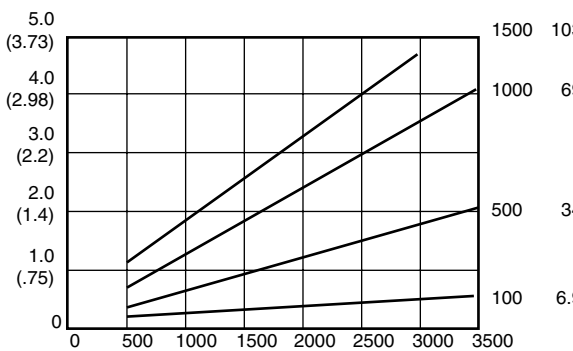

47B1 - R or L

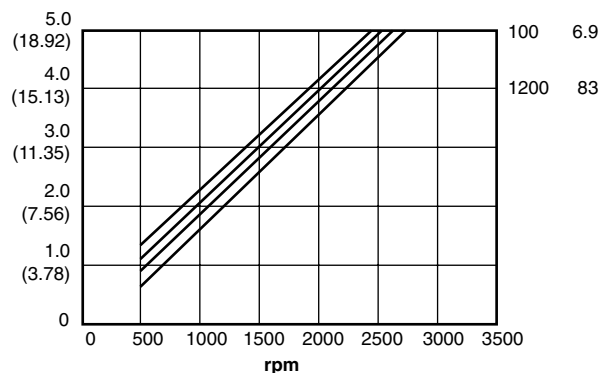
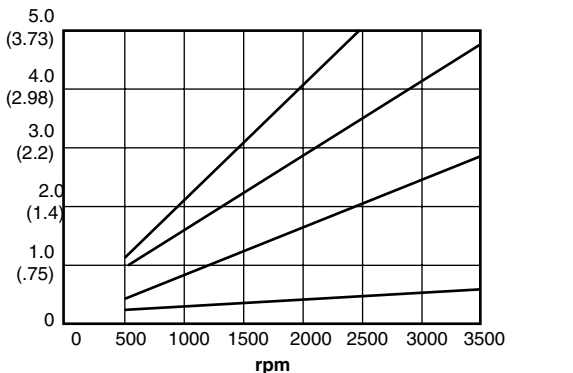

Quality Hydraulic Components from the Webtec Range

Typical Performance Curves

'B' Series Pumps

Note: These curves depict maximum working pressures. Pressures shown in order code are full-flow relief set pressures.

130 SSU Hydraulic Oil @ 120°F

59B1 - R or L

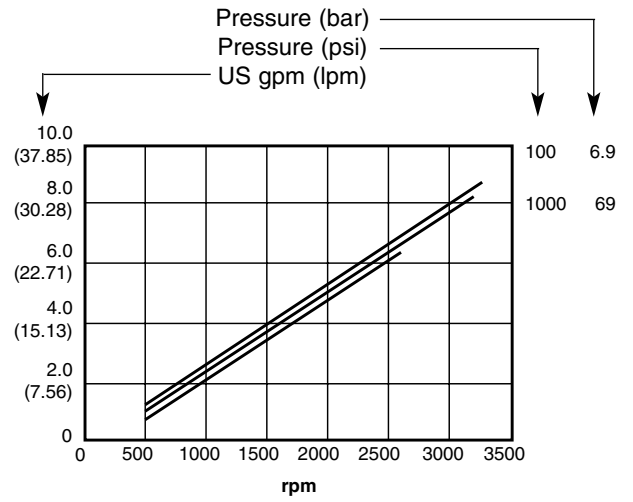
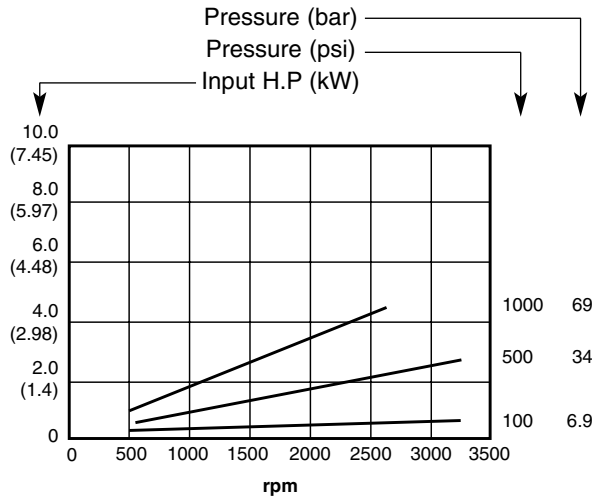

Quality Hydraulic Components from the Webtec Range

'B' Series Pumps as Replacements for 'LAS' Series

'B' Series pumps can be used as replacements for the obsolete 'LAS' Series and the following can be used with the A45Q1 foot mount.

Coding

03B1H16RX-R Replaces OLAS-R
 03B1H16RX-L Replaces OLAS-L
 04B1H16RX-R Replaces 1LAS-R
 15B1H15RX-R Replaces 3LAS-R
 15B1H15RX-L Replaces 3LAS-L

Displacement

03B = 0.03 in³/Rev
 04B = 0.04 in³/Rev
 15B = 0.15 in³/Rev

OLAS = 0.029 in³/Rev
 1LAS = 0.044 in³/Rev
 3LAS = 0.143 in³/Rev

Pump Code	Dim 'A'	Dim 'B'	Dim 'C'
03B	77.97mm	61.98mm	1/4" NPTF
04B	73.15mm	57.15mm	1/4" NPTF
15B	76.45mm	60.45mm	3/8" NPTF

Installation Details

Dimensions in millimetres

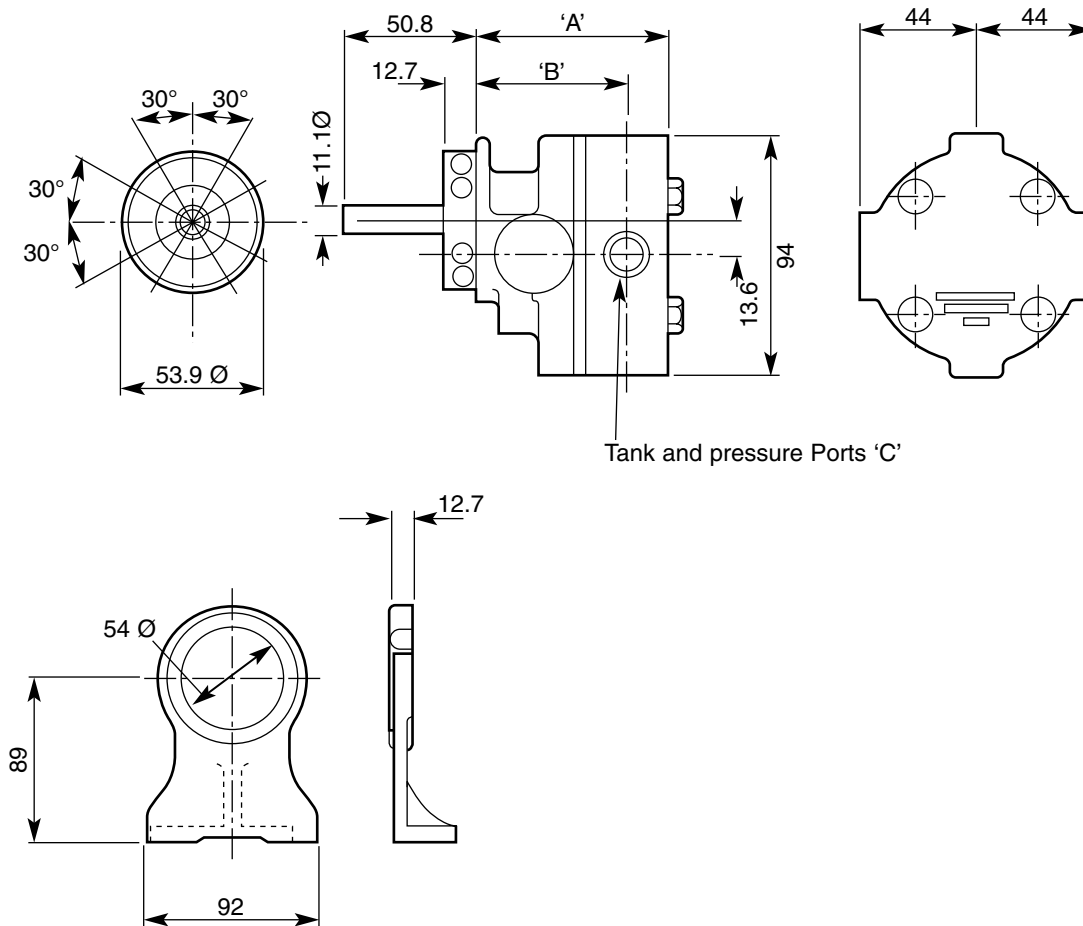

Quality Hydraulic Components from the Webtec Range

Typical (i.e. not absolute) Performance Curves

03B Pump

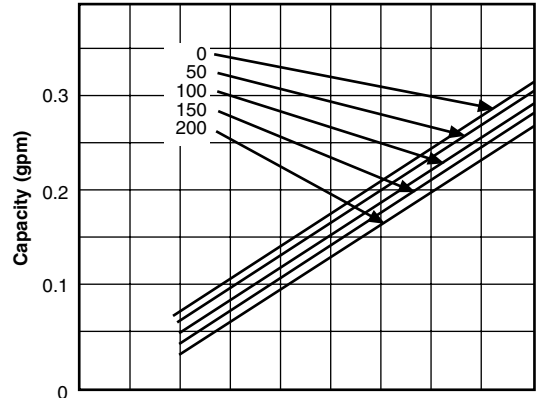
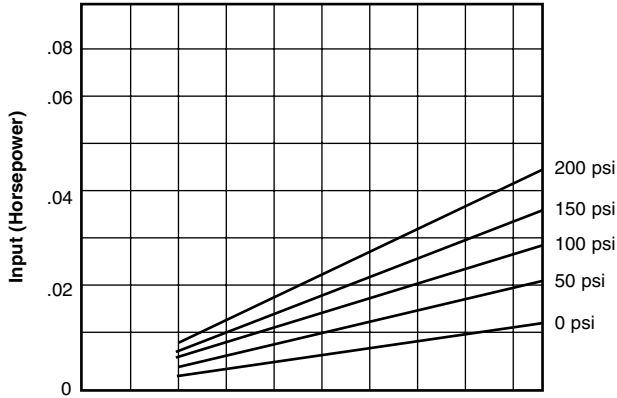

04B Pump

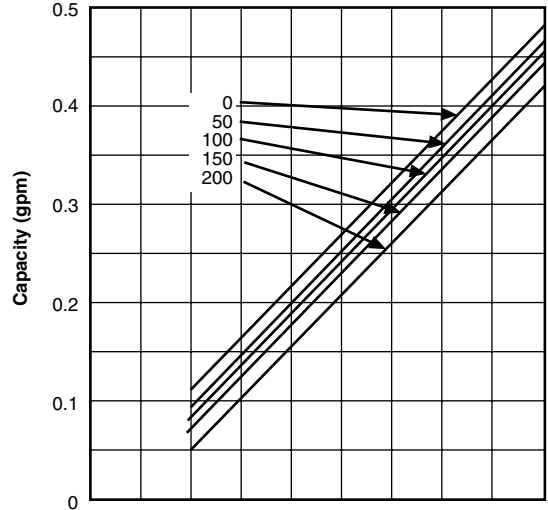
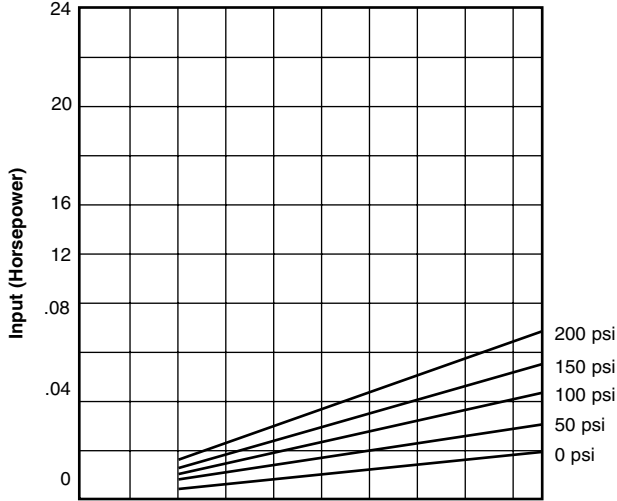

15B Pump

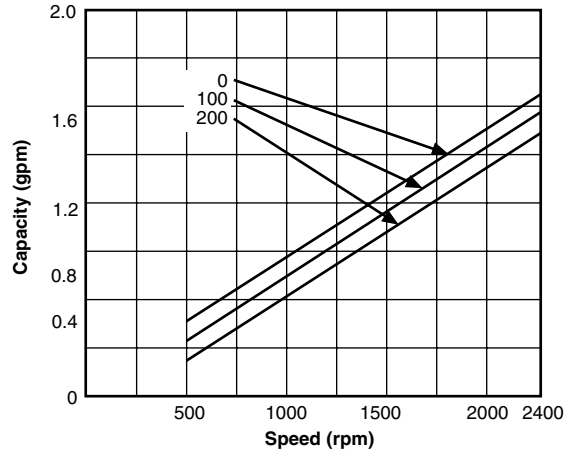
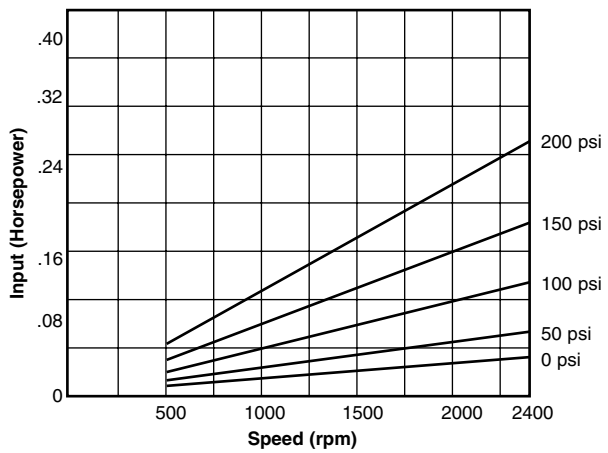

*SAE No. 10 Oil @ 100°F

YB Series

Gear Pump 2.5 to 12 cc/rev Capacity

An **EXTERNAL GEAR PUMP** consists basically of a drive gear (rotated by an external source via a shaft) and a meshing driven gear in a housing with an inlet and an outlet port. Fluid is forced through the pump as it becomes trapped between the rotating gear teeth and the housing. Because the output per revolution is based on the fixed volume displaced by the gears, the flow rate may be varied only by varying the gear speed.

Symbol

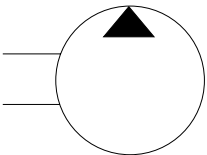

Features

- Customer can select from 6 standard displacements ranging from 2.5 to 12 cc/rev with pressures to 172 bar and speeds to 4000 rpm.
- Positive displacement pressure balanced gear type pumps for use with non-corrosive liquid with lubricating properties.
- Light weight, compact and sturdy construction, is ideally suited to machine tool and mobile equipment circuits.
- Durable die cast aluminium housing, combination two bolt/four bolt flange mounting needle bearings and optional internal relief valve and check valve on discharge contribute to overall efficiency and dependability.
- Internal relief valve drain eliminates the drain port. External relief valve drain is available in which case oil must be returned to tank below the fluid surface.
- Square keyed shafts are standard with tang shafts available as an option.

Quality Hydraulic Components from the Webtec Range

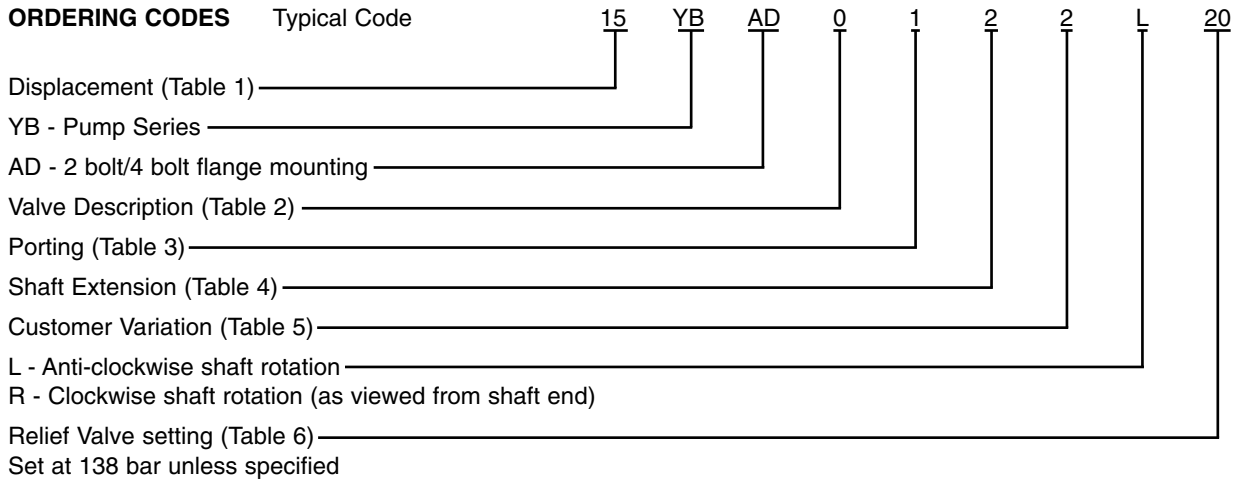

Specifications

Maximum Pressure:

138 bar continuous
172 bar intermittent

Mounting:

Combination 2 bolt/4 bolt

Capacity:

2.5-12 cc/rev (see Table 1, ordering codes)

Seals:

temperature and dirt resistant double lip shaft seal.

Maximum Speeds:

4000 rpm

Valves:

(optional) - internal check valve available on discharge for 15 - 29 series only - internally or externally drained relief valves available on all models - see Table 2, ordering codes for further details

Porting:

side standard (end optional) see Tables 3 & 5, ordering codes for further details

Shafts:

straight key shafts standard; tang shaft optional (see installation details)

Weight:

0.79 kg to 1.36 kg

Table 1: Displacement

Code	Displacement	Gear Width
15	2.5 cc/rev	6.4 mm
22	3.6 cc/rev	9.5 mm
29	4.8 cc/rev	12.7 mm
43	7.0 cc/rev	19.1 mm
58	9.5 cc/rev	25.4 mm
73	12.0 cc/rev	31.8 mm

Table 2: Valve Descriptions

Code	Description
0	No Relief or Check Valve
5	Relief and Check Valve - Internal Drain 15 - 29YB
6	Relief and Check Valve - External Drain 1/4" NPTF 15 - 29 YB

Relief valve cracking pressure adjustable between 0.7 bar and 138 bar on 15 - 29YB models and between 13.8 bar and 138 bar on 43 - 73 bar.

Maximum stable flow through relief valves - 23 lpm

External drain must be used when relief valve cycles frequently or for extended periods

Table 3: Porting

Code	Description
1	3/8" NPTF, side, Tank and Press (15 - 29YB)
3	1/2" NPTF, side, Tank 3/8" NPTF side Press (43 - 73YB)

Note: These are max. port sizes. Straight thread ports are available

Table 4: Shaft Extensions

Code	Description
2	Straight with Square Key Slot.
3	Tang

Table 5: Variations

Code	Description
2	Outboard Bearing
3	BSP Ports

Table 6: Relief Valve Settings

Code	Settings
01	7 bar
02	13.8 bar
20	138 bar

Quality Hydraulic Components from the Webtec Range

Installation Details for 15 - 29YB Pumps

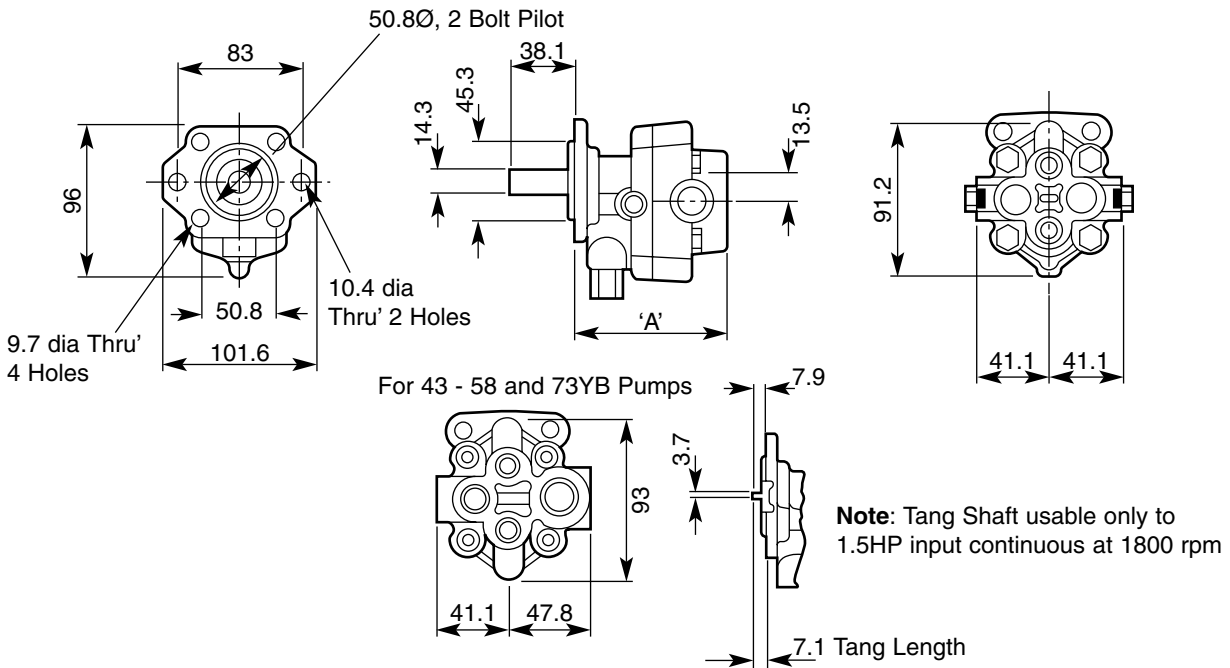

	15YB	22YB	29YB	43YB	54YB	73YB
Dim 'A'	82.5	88.9	88.9	95.2	101.6	107.9

Typical Performance Curves

Curves established using hydraulic mineral oil with viscosity of 27.4 centistokes at 49°C

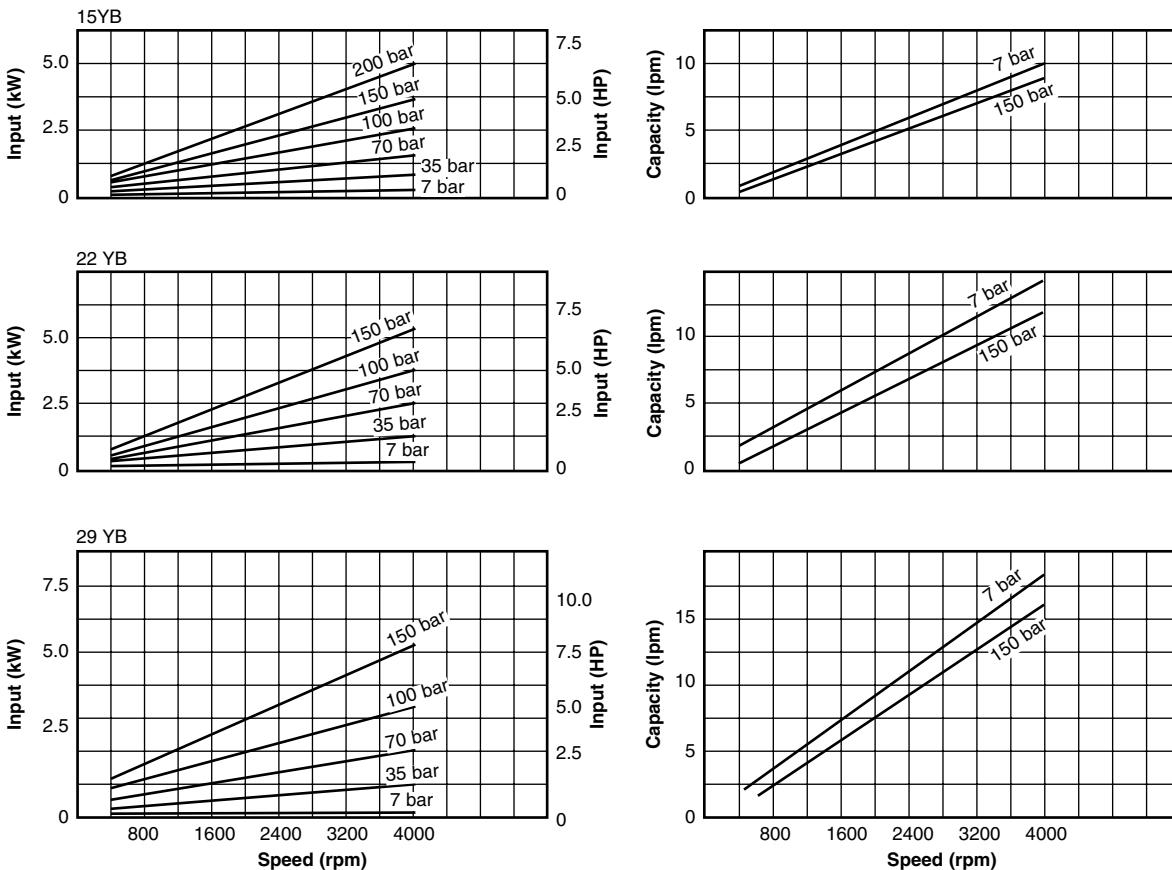

Quality Hydraulic Components from the Webtec Range

Typical pump Performance Curve (continued)

Curves established using hydraulic mineral oil with viscosity of 27.4 Centistokes at 49°C

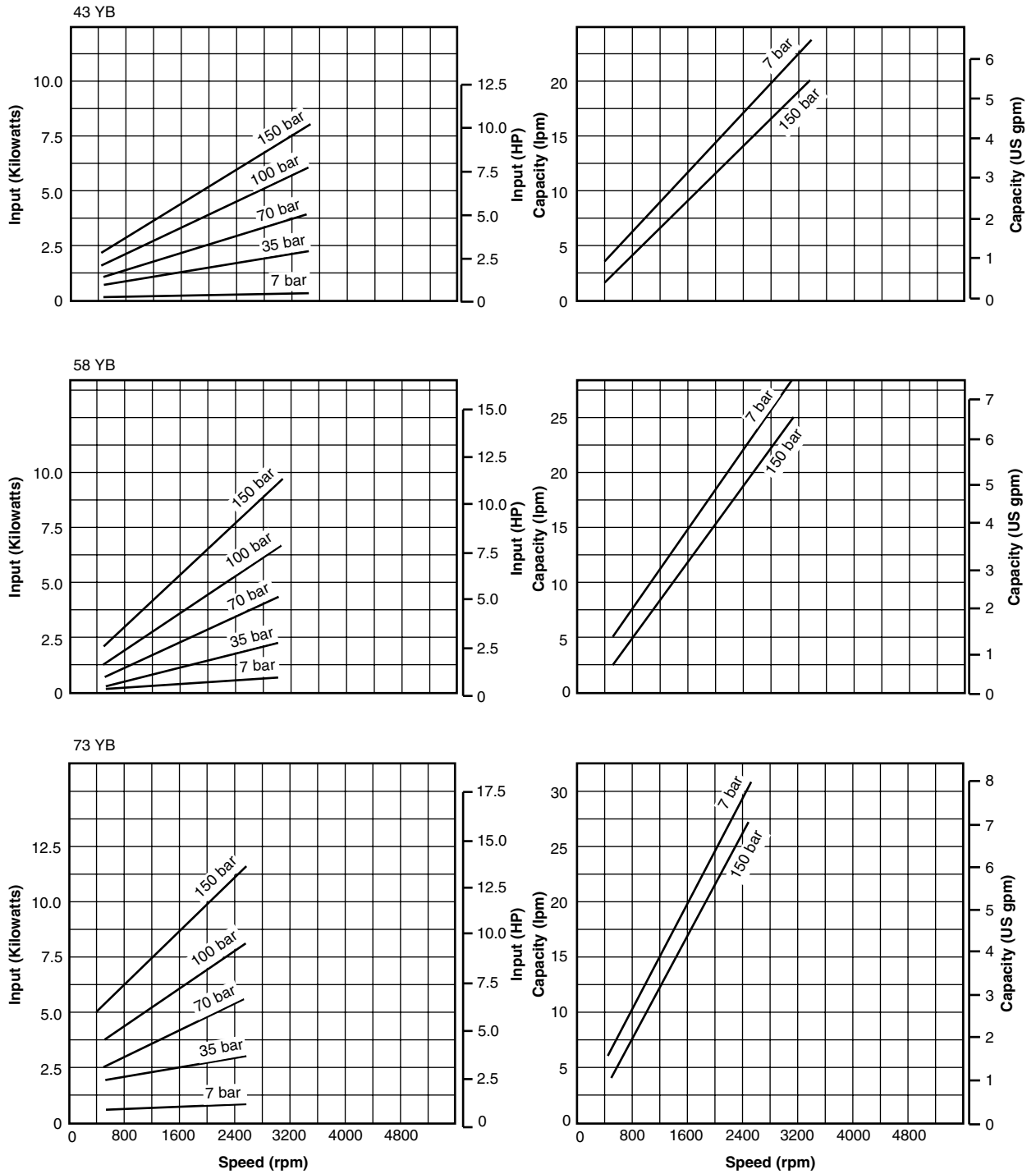

HCS Series

Hydraulic Gear Pumps 12 to 32 cc/rev Capacity

An **EXTERNAL GEAR PUMP** consists basically of a drive gear (rotated by an external source via a shaft) and a meshing driven gear in a housing with an inlet and outlet port. Fluid is forced through the pump as it becomes trapped between the rotating gear teeth and the housing. Because the output per revolution is based on the fixed volume displaced by the gears, the flow rate may be varied only by varying the gear speed.

Specifications

Maximum Pressure:
103 bar

Capacity:
12-32 cc/rev (see Table 1, ordering codes)

Maximum Speed:
2400 rpm

Porting:
inlet and outlet: 3/4" - 14 NPT drain: 1/4" - 18 NPT.

Weight:
6.0 kg to 8.0 kg

Mounting:
SAE type 'A' 2-bolt standard. For optional foot mount 33020-1 consult bulletin FP39-1 available from Webtec Hydraulics

Shaft:
Straight keyed shaft, standard

Seals:
temperature and oil resistant double lip seals, standard - viton or mechanical (face) seals available at extra cost.

Symbol

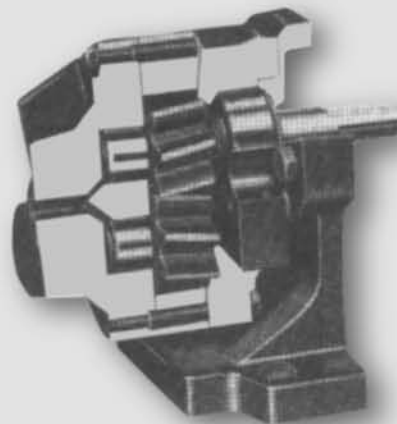
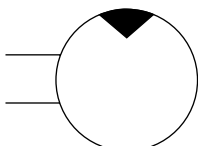

Features

- Customer can select from 4 standard displacements ranging from 12 to 32 cc/rev with pressures to 103 bar and speeds to 2400 rpm.
- Positive displacement pressure balanced gear type pumps for use with non-corrosive liquids with lubricating properties.
- Compact and rugged cast iron housings, designed for extra strength, are assembled for even distribution of pressure loads.
- Double-row ball bearing absorbs compound driving thrust and heavy duty needle bearing assure high mechanical efficiency.
- Uni-directional rotation permits internal bleeding thus eliminating the drain port*. Bi-directional rotation requires external draining.
- Temperature and oil resistant double lip type seals are standard. Viton or mechanical (face) seals are available at extra cost.
- Suitable for mining and underground use when fitted with Steel Pilot Plate.
- * For installations of this type clockwise (RH) or anti-clockwise (LH) when looking at the shaft end of the pump should be specified

Quality Hydraulic Components from the Webtec Range

ORDERING CODES Typical Code

Displacement (Table 1) _____

HCS - Pump Series _____

Rotation if internal Drain is required _____

Pilot Plate
 S = Steel
 A = Aluminium

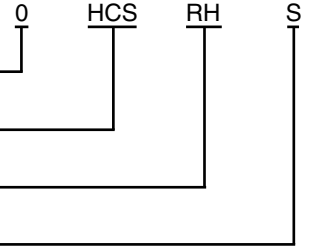

Installation Details

Dimensions in millimetres

	0HCS	1HCS	2HCS	3HCS
Dim A.	96.8	100.8	107.2	112.0

Table 1: Displacement

Code	Displacement
0	12.6 cc/rev
1	17.5 cc/rev
2	25.1 cc/rev
3	31.3 cc/rev

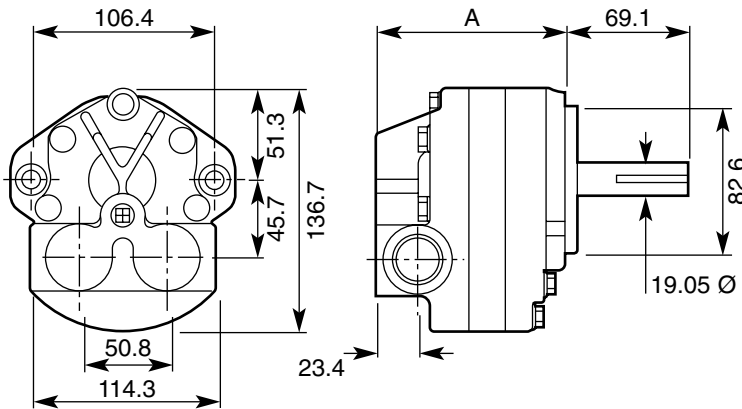

Typical Pump Performance Curves

Curves established using Type 'A' automatic transmission oil at 49°C

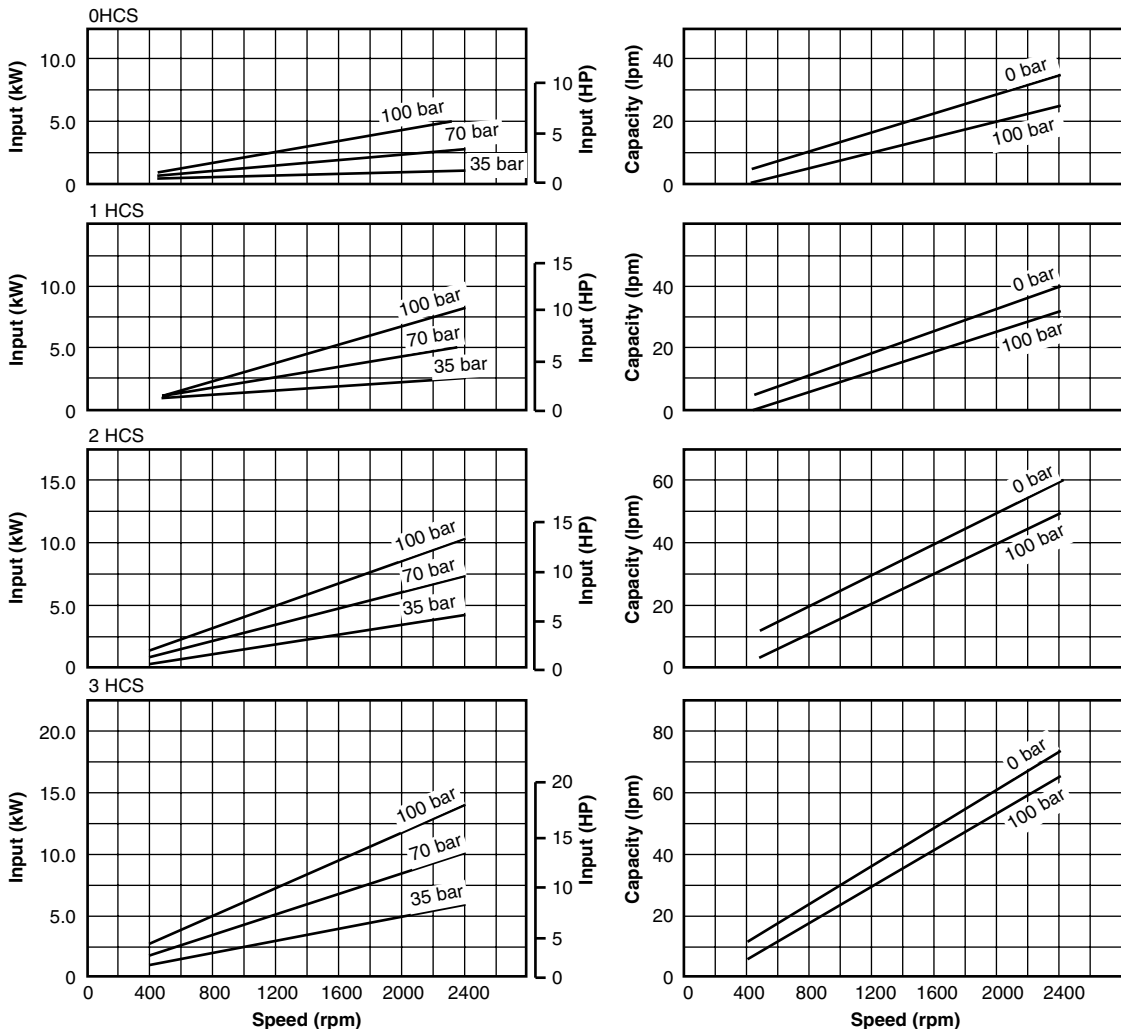

YC Series

Gear Pumps 12 to 32 cc/rev Capacity

An **EXTERNAL GEAR PUMP** consists basically of a drive gear (rotated by an external source via a shaft) and a meshing driven gear in a housing with an inlet and an outlet port. Fluid is forced through the pump as it becomes trapped between the rotating gear teeth and the housing. Because the output per revolutions is based on the fixed volume displaced by the gears, the flow rate may be varied only by varying the gear speed.

Specifications

Maximum Pressure:
210 bar

Capacity:
12-32 cc/rev

Maximum Speeds:
3000 rpm

Porting:
BSPF side ports standard

Weight:
to 3.75 kg

Mounting:
YCA-SAE type A, 2 bolt flange

Wear Plate:
pressure balanced, steel backed bronze

Bearings:
4 special sleeve type

Gears:
smooth running spur, heat treated alloy steel

Seals:
double-lip on drive shaft

Housing:
high duty aluminium

Flow divider:
(optional)

Symbol

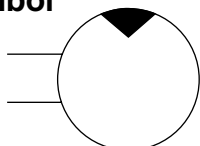

Features

- Customer can select from 4 standard displacements ranging from 12 to 32 cc/rev with pressure to 210 bar and speeds to 3000 rpm.
- Positive displacement pressure balanced gear type pumps for use with non-corrosive liquids with lubricating properties.
- Pressure balanced wear plate gives high volumetric efficiency and prevents clearance changes due to operating heat.
- Seal chamber pressures are low, eliminating seal leaks and internal thrust bearing loads.
- Internal drain eliminates the need for an external drain line.
- Optional flow divider manifold allows a pre-set constant flow of oil at the regulated port.
- Exceptionally compact design combined with high efficiency makes the YC series ideal for hydraulic applications where space is at a premium and weight is a critical factor.

Quality Hydraulic Components from the Webtec Range

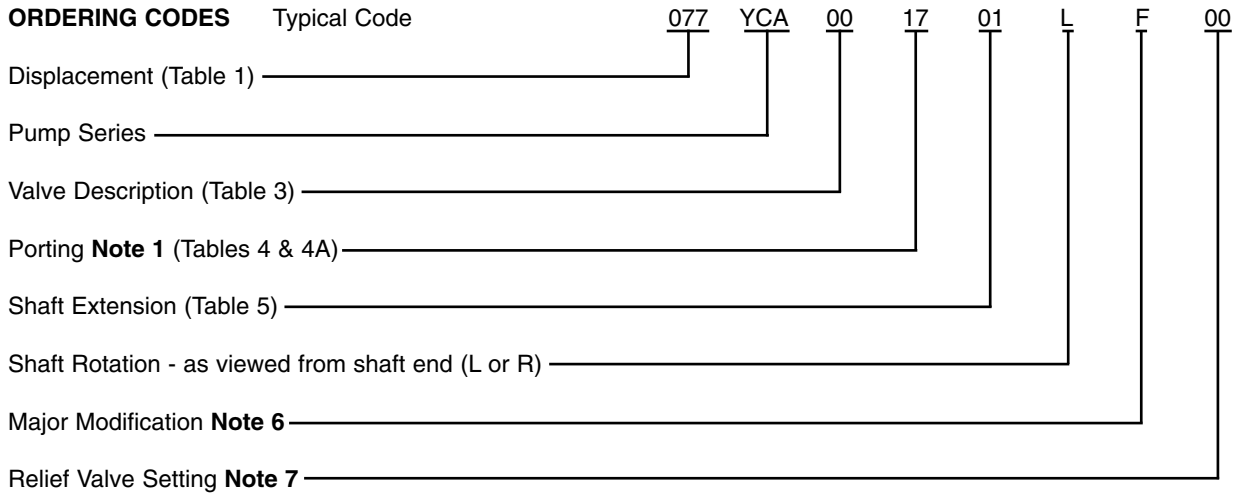

Table 1: Displacement

Code	Pump Displacement		Gear Width	
	cc/rev	in ³ /rev	mm	ins
077	12.62	0.77	12.70	0.50
116	19.01	1.16	19.05	0.75
155	25.40	1.55	25.40	1.00
194	31.79	1.94	31.75	1.25

Table 3: Valve Description

No.	Description
00	No relief or check valve valve (no manifold)
01	Priority flow divider assembly. 11.4 lpm
02	Priority flow divider assembly. 18.9 lpm
05	Priority flow divider assembly. 3.8 lpm
06	Priority flow divider assembly. 22.6 lpm
07	Priority flow divider assembly. 26.4 lpm
08	Priority flow divider assembly. 30.2 lpm
09	Priority flow divider assembly. 34.0 lpm
10	Priority flow divider assembly. 7.6 lpm
11	Priority flow divider assembly. 15.2 lpm

Table 4: Porting (Pumps without Manifolds)

No.	Description
80	Tank 3/4" BSPF side - Press 1/2" BSPF side (Standard on all pumps)
17	Tank 1-1/16" - 12 side - Press 7/8" - 14 side (pumps 077 & 116)
21	Tank 1-3/16" - 12 side - Press 7/8" - 14 side (pumps 155 & 194)

Table 4a: Porting (Pumps with manifolds)

No.	Description
04	Tank 1-1/16" - 12 side - Pri & Sec 7/8" - 14 side (pumps 077 & 116)
11	Tank 1-3/16" - 12 side - Pri & Sec 7/8" - 14 side (pumps 155 & 194)
81	Tank 3/4" BSP - Pri & Sec 1/2" BSP

Table 5: Shaft Extension

No.	Description
01	Straight w/square key slot
02	Splined 5/8" OD - 9 tooth

Note 6. 'F' code designates design modification.

Note 7. On all pumps incorporating a flow divider, pump code must indicate priority relief valve pressure setting which is to be indicated as follows: 01 = 100, 02 = 200 etc. These digits represent desired relief valve settings in psi divided by 100 (100 psi = 6.89 bar).

Quality Hydraulic Components from the Webtec Range

Installation Details

Dimensions in millimetres

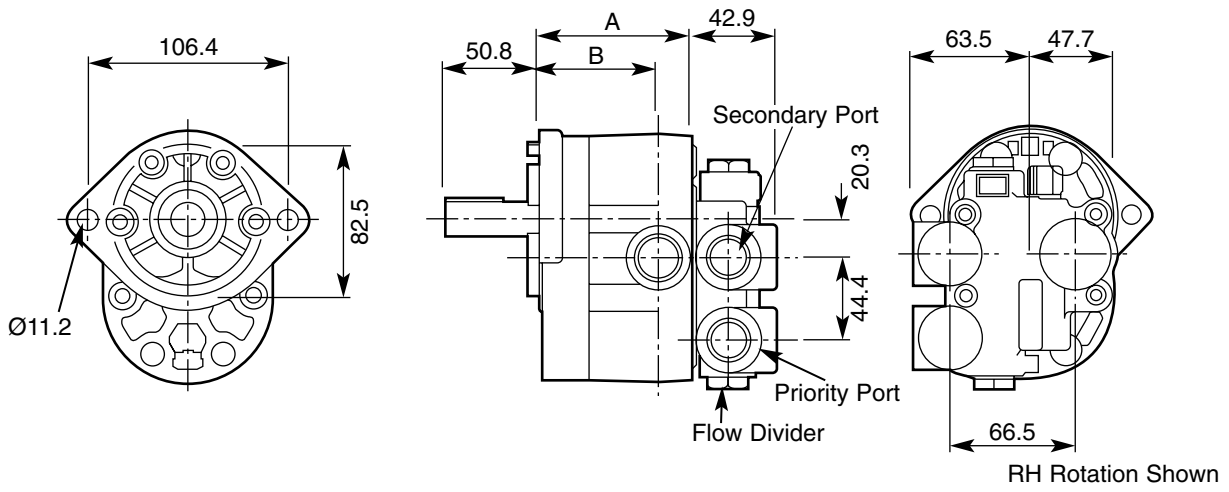

Pump	077	116	155	194
A	71.37	77.72	84.07	90.42
B	51.82	58.17	64.52	70.87

Quality Hydraulic Components from the Webtec Range

Typical pump Performance Curves

Curves established using SAE No. 10 oil at 50°C

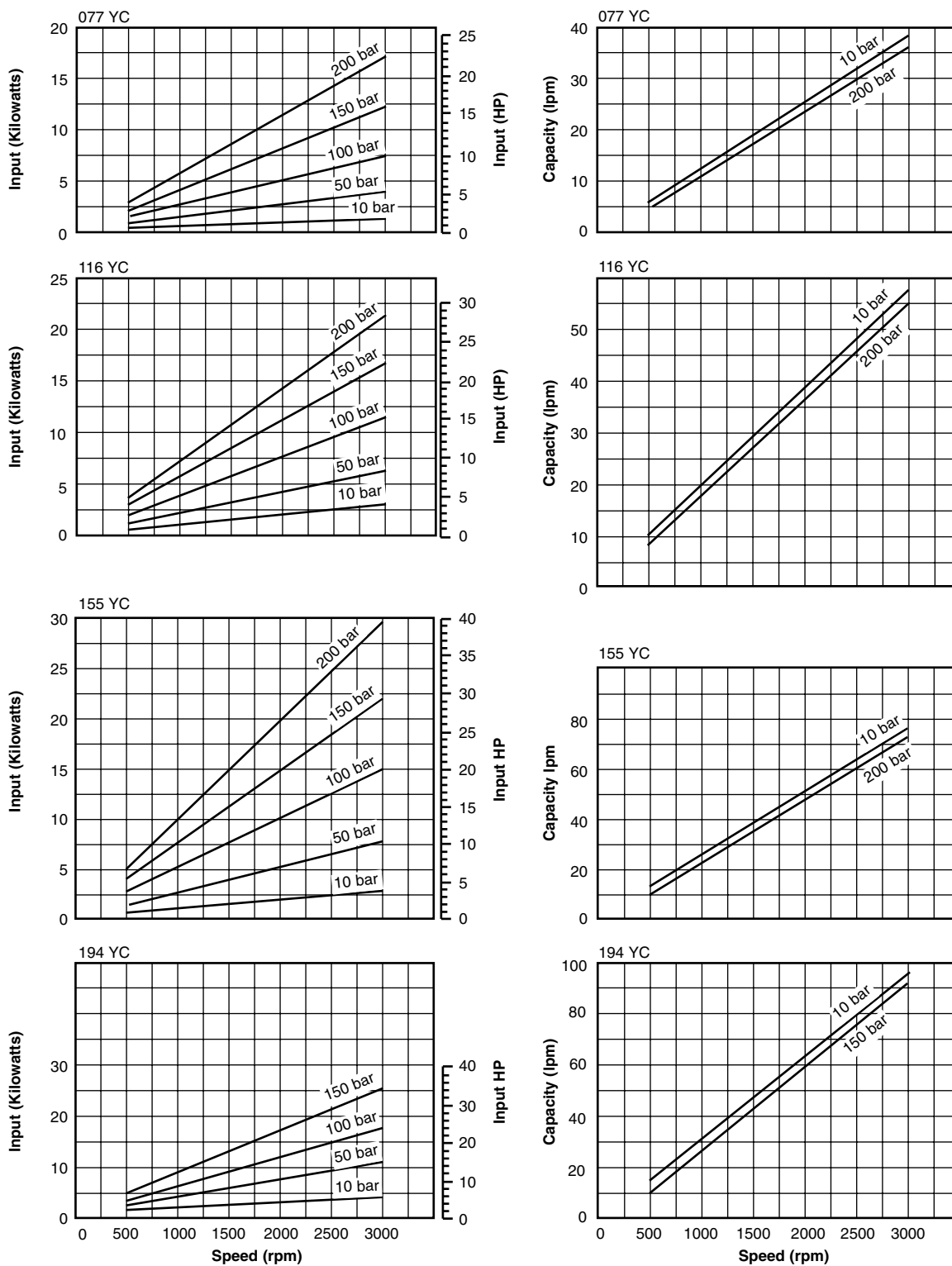

NOTES

Manufacturers of Hydraulic Components and Test Equipment for the Mobile, Industrial and Agricultural Industries



Your Webtec Products representative:



WEBTEC PRODUCTS LIMITED

Nuffield Road, St. Ives, Cambridgeshire, PE27 3LZ, UK
Tel: +44(0)1480 397400 Fax: +44(0)1480 466555

E-mail: sales@webtec.co.uk
See us at: www.webtec.co.uk



Webtec Products Limited reserve the right to make improvements and changes to the specification without notice.