



WEBTEC PRODUCTS LIMITED

Product Update Spring 2005

Welcome to the Spring 2005 update.

Based on your feedback we are constantly looking at ways to improve our products through continuous research and development. This year will be no exception with the launch of the new **DHM403** Digital Hydraulic Multimeter and the **CT1300** turbine flow meter. These two new products cater for mobile and industrial applications respectively. Building on over 30 years experience of manufacturing accurate and reliable hydraulic test equipment, the **DHM403** and **CT1300** provide hydraulic engineers with an invaluable aid in monitoring and maintaining the efficiency of increasingly complex hydraulic systems simply and cost effectively.

Webtec hydraulic components also continue to provide quality performance and reliability. Focus here is on our wide range of flow dividers and directional control valves which are suitable for a wide variety of mobile, industrial and agricultural applications.

Don't forget, our website is constantly updated with all the latest product news and technical bulletins to download – see for yourself at www.webtec.co.uk.

Come and visit us at



11 – 15 April 2005

Messegeelaende, Hannover, Germany

The world's leading showcase for industrial technology,
bringing together eleven world-class trade fairs in a single venue.

Hall 21 Stand D10-1
(part of the BFPA group stand)

For more information see
www.hannovermesse.de

**Manufacturers of hydraulic components
and test equipment for the mobile, industrial
and agricultural industries**



**New DHM Digital
Hydraulic Tester**



**New CT 1300
Turbine Flow Meter**



**Pumps & Motors
available again**

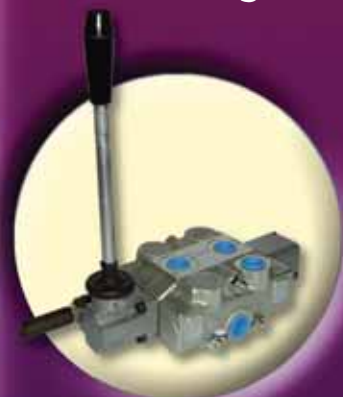

**Directional Control
Valves**

Don't miss two
NEW product previews:
DHM403 & CT1300

Introducing the new DHM403



- Accurately measure 5 parameters simultaneously
- Display all readings digitally on one screen
- Easy to use design
- Robust design for use in extreme conditions

Measure:

Flow, pressure, peak pressure, temperature, power and pump efficiency

Digital screen



Analogue screen



Volumetric efficiency screen



As seen in iVT Magazine
Feb/March 2005

CT CONDITIONED OUTPUT TURBINE FLOW METERS

- Monitor system flow, pressure & temperature in one compact unit
- Install permanently in pressure or tank line – only break into your system once to minimise contamination
- Choice of 4 signal types for flow measurement – 4-20mA, 0.5V DC, frequency (TTL) or sensor recognition (SR)
- Full range of accessories, temperature sensors, pressure sensors, readouts.

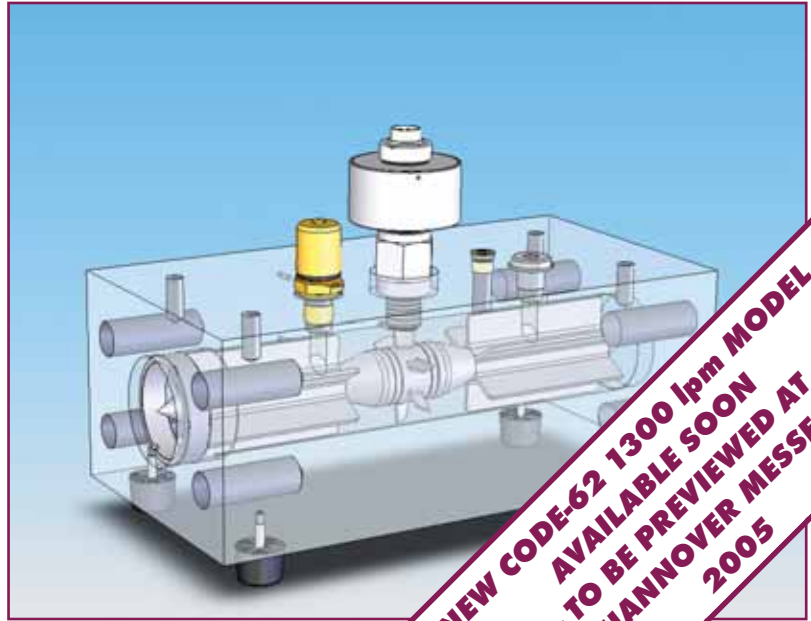

WEBSTER GEAR PUMPS and MOTORS AVAILABLE AGAIN from



B – A range of cast-iron compact gear pumps & motors available in 9 sizes from 0.11 – 0.74 cu.in/rev. Suitable for mobile equipment, mining and underground use.

HCS – A range of rugged cast iron gear pumps and motors available in 4 sizes from 0.77 – 1.91 cu.ins / rev. Fitted with helical gears for quiet operation. Suitable for mining and underground use.

YB – A range of compact, lightweight aluminium gear pumps and motors available in 6 sizes from 0.15 – 0.73 cu.in / rev. Suitable for mobile equipment, lawn and turf machinery and fan drive systems.

KB – A range of very flexible and rugged gear pumps and motors with a three piece aluminium & cast iron construction. Available in 9 sizes from 0.86 – 3.88 cu.in / rev. Suitable for mobile equipment.

YDA – A range of gear pumps and motors of aluminium and cast iron construction. Available in 5 sizes from 0.64 – 2.37 cu. Ins / rev. Available with flow divider. Suitable for a wide range of applications.

YC – A range of versatile, powerful aluminium gear pumps and motors available in 6 sizes from 0.58 – 1.94 cu.in / rev. Suitable for mobile equipment. Can be fitted with flow divider end cover.

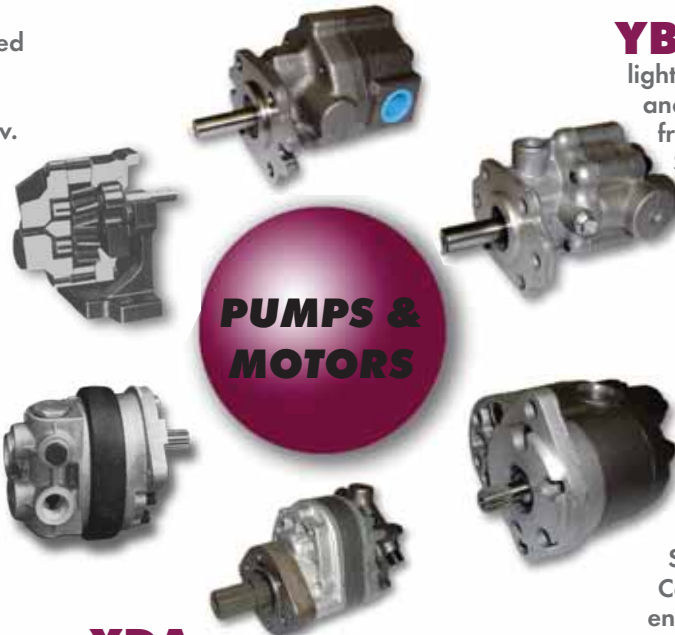

In addition, Webtec are also able to supply many replacement special type pumps and motors which are fitted to major OEM's mobile machines, including the 237 YDA special Matbro Pump (P19196)

**Would you like to supply two circuits from one pump?
Do you need to control precisely the speed of a motor or cylinder?**

You can now using variable priority flow dividers from Webtec

VFD50



FDM



2FV2V



Flow dividers with relief valve or check valve built-in, as well as high pressure and 4-20 mA remote control versions available.

RV2FV2V



Our range of flow dividers are available with a wide range of options to suit your application.

HP2FV2V



CK2FV2V





Fax Back

For further information on any of the products featured in this product update please complete the following:

Webtec Hydraulic Components

- Flow Dividers
 Webster Gear Pumps / Motors
 Directional Control Valves

Webster Hydraulic Test Equipment

- DHM403
 CT Series
 Overview of Webster Test Eqpt

I would like one of your engineers to call me to discuss my requirements for:

- Hydraulic Components Hydraulic Test Equipment

Please complete your details below so we know who to contact with the requested information.

Do we have the correct details? Please use the spaces below to tell us if we need to amend our records.

Fax back this form to **01480 466 555**

Name: _____

Company: _____

Position in Company _____

Address: _____

Telephone _____

Fax: _____

email: _____

Please register my e-mail address for e-updates

If you would prefer not to receive further product updates and details of any future special offers please tick this box

and complete your details before faxing back to us.

Complete this fax back and we will send you a **FREE** metric conversion & hydraulic equation guide

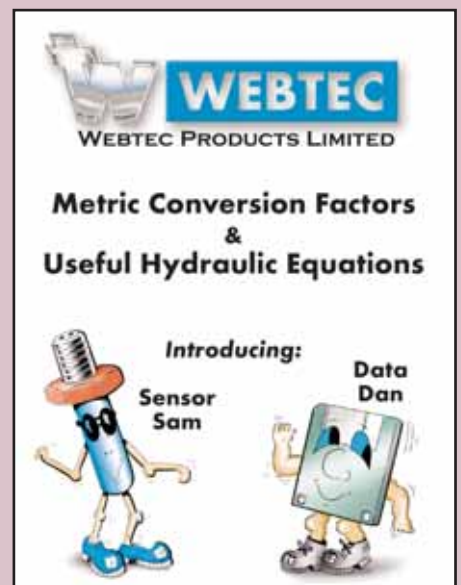

**Introducing the new
DHM Digital Hydraulic Tester**



**Product Update
Spring 2005**

Directional control valves

**Do you need a specialist directional control valve for your application?
Are you looking for a replacement for an old model?**

Look no further as Webtec manufactures a wide range of specialist and customised valves.



180



1/2"



SV80



R type



S type

Suitable for applications ranging from high-pressure near zero-leakage conditions to specialist cam operated functions and custom manifold options. Please contact us to discuss your application.



WEBTEC PRODUCTS LIMITED

**Nuffield Road, St. Ives, Cambridgeshire, PE27 3LZ, UK
Tel: +44(0)1480 397444 Fax: +44(0)1480 466555**



**email: sales@webtec.co.uk
See us at: www.webtec.co.uk**



Certificate No.8242

Webtec Products Limited reserve the right to make improvements and changes to the specification without notice.