



**WEBTEC**

**WEBTEC PRODUCTS LIMITED**



# **Hydraulic Hand Pumps**

**Hydraulic Hand Pumps**

**Quality Hydraulic Components  
from the Webtec Range**



# CONTENTS

	<b>DESCRIPTION</b>	<b>PAGE No.</b>
	<b>WHP-14 Series Hand Pumps</b>	<b>1</b>
	<b>WPM-20 without Tank</b>	<b>3</b>
	<b>WPM-25 Series Hand Pumps</b>	<b>5</b>

# WHP Series Hand Pumps 14cc

The totally enclosed all weather construction of the WHP Series hand pumps offers rugged trouble free operation in a wide variety of agricultural, industrial, mobile, and mining applications.

## Specifications

**Maximum Pressure:**

210 bar

**Reservoir Capacity:**

1.7 to 9.0 litres

**Pump Output:**

14cc/double stroke

**Service Port:**

3/8" BSPF

**Material:**

Cast iron body  
Steel internal parts case hardened  
Steel tank

**Weight:**

8.5 kg

## Symbol

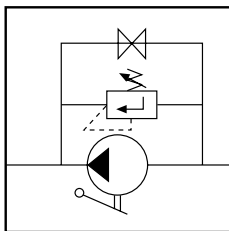

## Features

- Choice of mounting bosses.
- Alternative handle positions.
- Externally adjustable relief valve.
- Double acting action.
- With or without reservoir.

# Quality Hydraulic Components from the Webtec Range

**ORDERING CODES**      Typical Code

Pump Type \_\_\_\_\_ WHP 14 3

Output cc/cycle \_\_\_\_\_

Tank Capacity in litres (Table 1) \_\_\_\_\_

**Table 1**

Code	Capacity	Dim. A	Dim. B	Dim. C	Part Number
2	1.7 litres	198	187	155	TSK 5229 - 2
3	3.4 litres	198	195	225	TSK 5229 - 3
4	4.5 litres	198	240	225	TSK 5229
9	9.0 litres	293	290	225	TSK 5229 - 1
G	No Tank	-	-	-	TSK 5229 - 4

## INSTALLATION DETAILS

Dimensions in millimetres

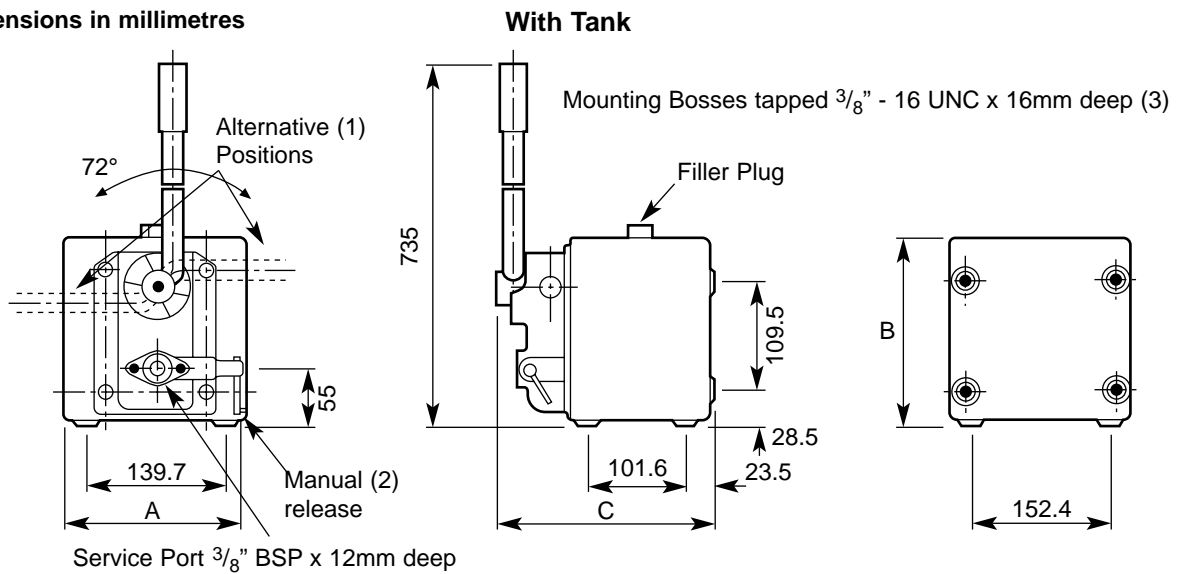

**Notes:**

- (1) Tighten Grubscrew into lever recess to lock desired position
- (2) Remove Crosspin to adjust Relief Valve
- (3) No Base Mounting Holes on 1.7 litre Reservoir

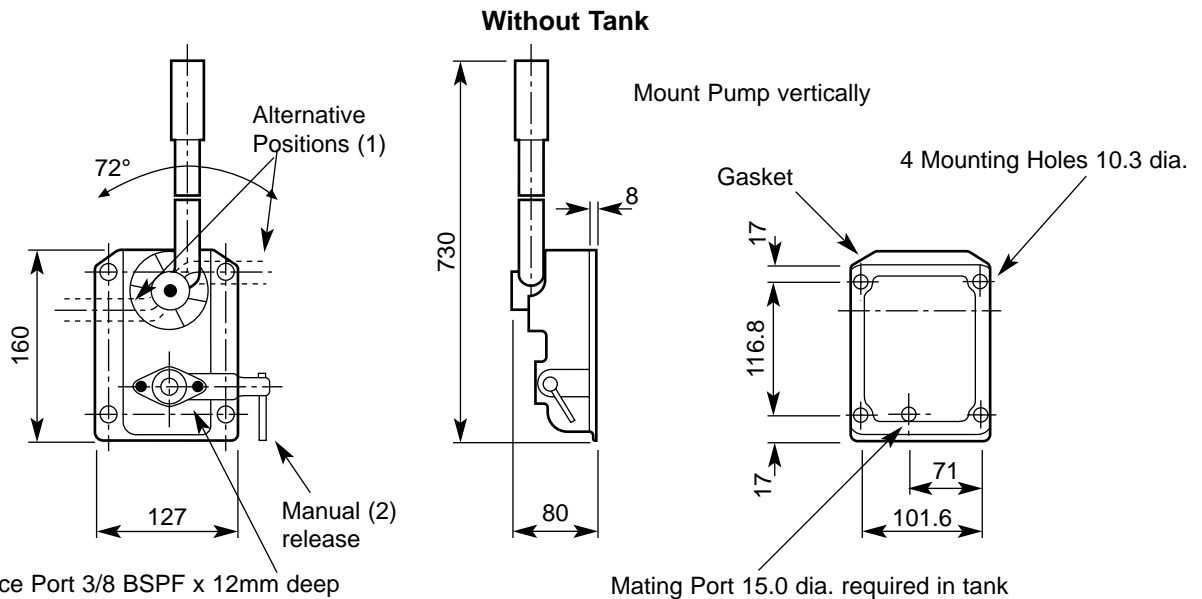

**Notes:**

- (1) Tighten Grubscrew into lever recess to lock desired position.
- (2) Remove Crosspin to adjust Relief Valve

# WPM Series Hand Pumps 20cc

This piston type Hand Pump offers rugged trouble free operation in a wide variety of applications.

Can be installed in any convenient position using oil from the existing system reservoir.

## Specifications

**Maximum Pressure:**  
300 bar

**Pump Output:**  
20 cc/double stroke

**Porting:**  
Suction/Input: 1/2" BSPF  
Delivery/Output: 3/8" BSPF

**Material:**  
Cast Iron Body

**Weight:**  
3.9 kg



## Features

- Easy lever control for raise and lower functions.
- Operate from existing system oil reservoir.
- Durable cast iron body.
- Simple installation.

# Quality Hydraulic Components from the Webtec Range

ORDERING CODES    Typical Code

Pump Type \_\_\_\_\_

Output cc/cycle \_\_\_\_\_

WPM

20

Part Number: TSK 4356 - 1

## INSTALLATION DETAILS

Dimensions in millimetres

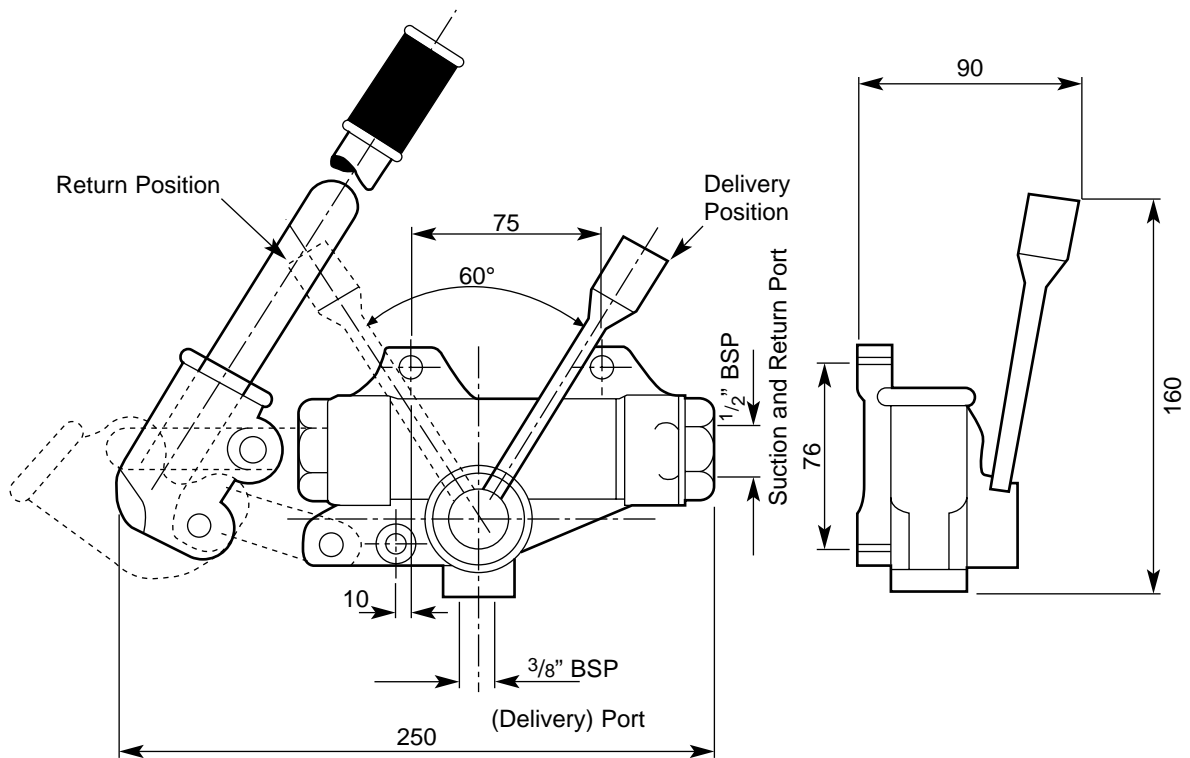

# WPM Series Hand Pumps 25cc

These piston-type hand pumps are completely self-contained for instant and rugged over all use. Lightweight construction ensures easy portability.

Each unit consists of an oil reservoir and an externally located release valve.

## Specifications

**Maximum Pressure:**  
300 bar

**Tank Capacity:**  
2 litres to 7 litres

**Pump Output:**  
25 cc/cycle

**Porting:**  
Service 3/8" BSPF

**Material:**  
Aluminium body and tank

**Weight:**  
5.4 kg

## Symbol

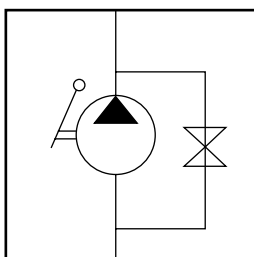

## Features

- With or without tank (Various tank sizes available)
- 2 standard operating positions.
- Durable aluminium body and tank.

# Quality Hydraulic Components from the Webtec Range

**ORDERING CODES**      Typical Code

Pump Type \_\_\_\_\_ WPM      25      S2

Output cc/cycle \_\_\_\_\_

Tank Capacity in Litres (see Table 1) \_\_\_\_\_

**Table 1**

Code	Capacity	Dim. A	Part Number
S2	2 litres	291	TSK 4356
S3	3 litres	341	TSK 4356 - 5
S5	5 litres	441	TSK 4356 - 3
S7	7 litres	576	TSK 4356 - 4

## TYPICAL PERFORMANCE

S = Load in kgf placed on end of lever  
P = Pressure in bar delivered by the pump

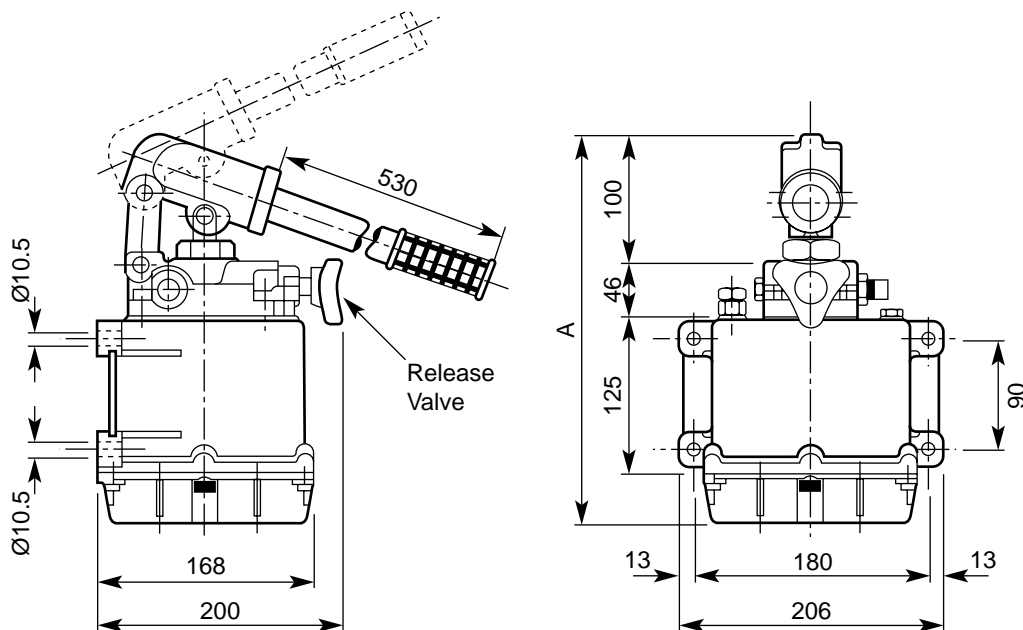
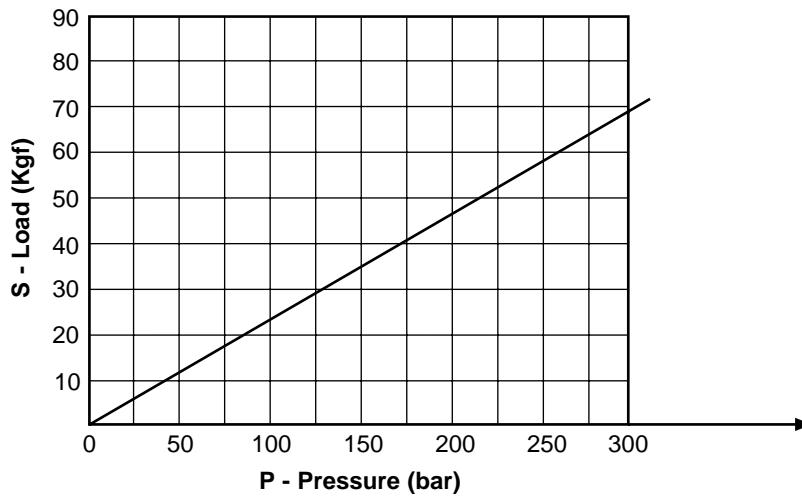





# Manufacturers of Hydraulic Components and Test Equipment for the Mobile, Industrial and Agricultural Industries



Your Webtec Products representative:



**WEBTEC PRODUCTS LIMITED**

Nuffield Road, St. Ives, Cambridgeshire, PE27 3LZ, UK

Tel: +44(0)1480 397400 Fax: +44(0)1480 466555

E-mail: [sales@webtec.co.uk](mailto:sales@webtec.co.uk)  
See us at: [www.webtec.co.uk](http://www.webtec.co.uk)



Certificate No.8242



Webtec Products Limited reserve the right to make improvements and changes to the specification without notice.