



**WEBTEC**

**WEBTEC PRODUCTS LIMITED**

# ***In-line Flow Indicators and Flow Indicator Kits***

***Measures Flow, Temperature  
and Pressure, ideal for Oil or  
Water based systems***



***Quality Hydraulic Test Equipment  
from the Webster Range***

***In-line Flow Indicators and Flow Indicator Kits***





# CONTENTS

	<b>DESCRIPTION</b>	<b>PAGE No.</b>
	<b>Introduction</b> Flow Indicators for Oil and Water	1
	<b>Low Cost In-Line Flow Indicator with built in Thermometer</b> 16 lpm; 30 lpm; 60 lpm; 120 lpm; 180 lpm	3
	<b>Low Cost In-Line Flow Indicator with built in Thermometer for Water or Oil</b> 30 lpm; 60 lpm; 120 lpm; 200 lpm; 400 lpm; Up to 420 bar	5
	<b>In-Line Flow Indicator with built in Thermometer</b> 200 lpm; 300 lpm; 400 lpm; 350 bar	7
	<b>RFI Reversible Flow Indicator with built in Thermometer</b> 120 lpm; 180 lpm; 200 lpm	9
	<b>In-Line Flow Indicator with Electrical Switch</b> 16 lpm; 30 lpm; 60 lpm; 120 lpm; 180 lpm	11
	<b>WP Series Flow Meter</b> Flow rates from 0.5 - 550 lpm Pressure Rating: 240 bar	13
	<b>WP Series Pneumatic Flow Monitor</b> For 1/4 - 1 1/2 Inch Pipe Size	15
	<b>WP Series Phosphate Ester Flow Monitor</b> Flow rates from 0.5 to 550 lpm Select from aluminium, brass or stainless steel	17
	<b>WP Series High Temperature Flow Monitor</b> Flow rates from 0.5 to 550 lpm Select from aluminium, brass or stainless steel	19

*Continued over page*

# CONTENTS

*Continued from previous page*

	<b>DESCRIPTION</b>	<b>PAGE No.</b>
	<b>WP Series Flow Monitor with Flow Rate Alarm</b> Hydraulic or pneumatic models available Select from aluminium, brass or stainless steel	21
	<b>Low Cost In-Line Flow Indicator Test Kit</b> 30 lpm; 60 lpm; 120 lpm; 180 lpm	23
	<b>RFIK Series Low Cost Hydraulic Tester</b> 120 lpm; 180 lpm - Up to 420 bar	25

**Quality Hydraulic Test Equipment from the Webster Range**

# **Applications**

**Hydraulic pump  
and system testing**

**For the Mobile, Industrial and  
Agricultural Industries**

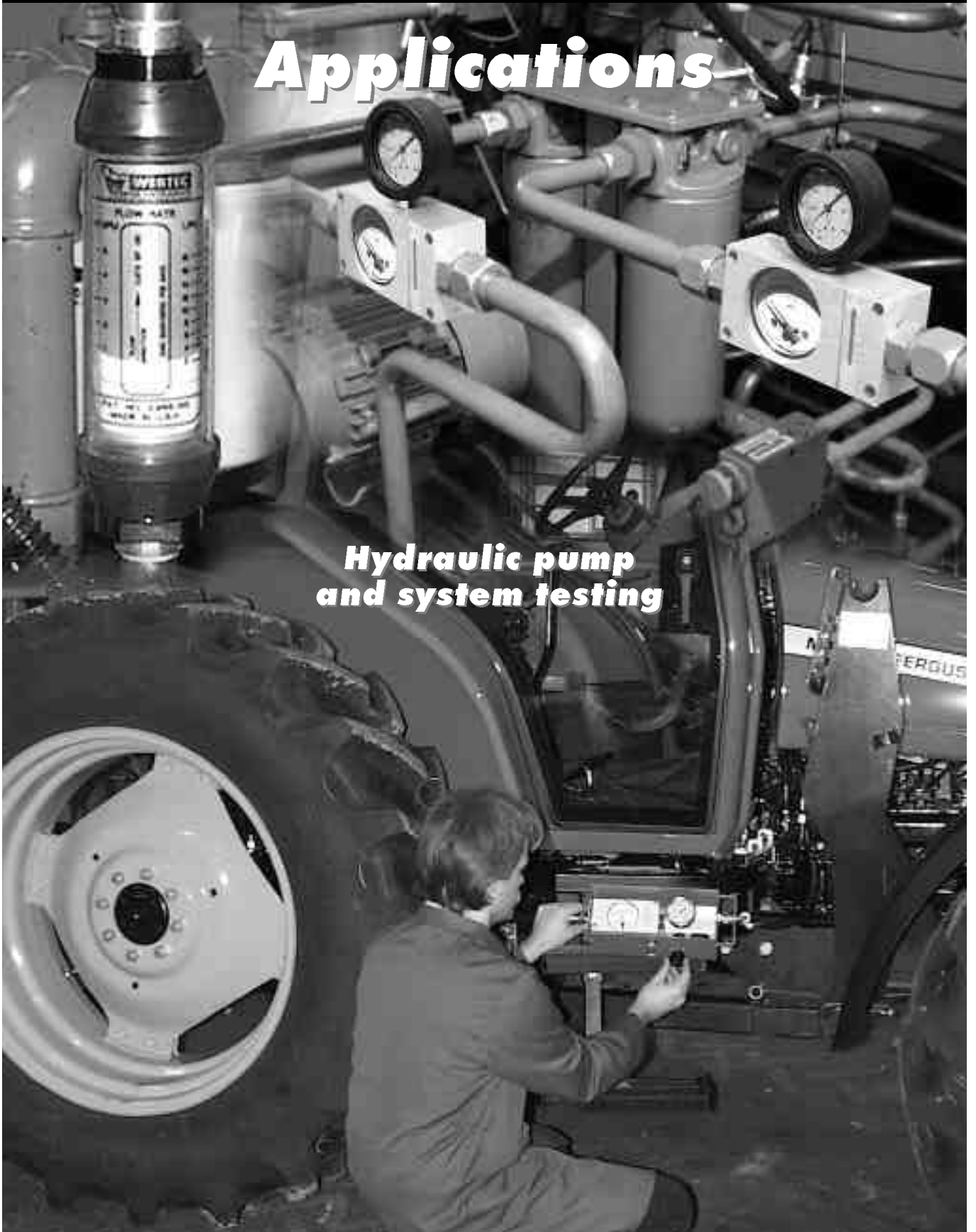

# INTRODUCTION

## FLOW INDICATORS FOR OIL AND WATER

- Mounted In-Line
- Built-in Thermometer
- Competitively Priced

The Webster flow Indicators are designed for continuous monitoring or intermittent use in commissioning and servicing hydraulic systems.

areas or on applications where no power is available. The flow indicator design ensures good reliability and minimises the effects of contamination.

The FI series large clear 63mm diameter dial ensures that quick checks can be made to determine pump performance and setting of flow control valves. Flow indicators can be used on mobile and industrial hydraulic circuits and also on lubrication and coolant systems that use oil/ water. These direct acting flow indicators can be installed in hazardous

The optional thermometer on FI series is set in rubber compound and angled deep into the block to sense the temperature changes in the fluid passage. For external protection the readout scales of both thermometer and flow indicator are recessed and shielded behind impact resistant plastic windows. The indicators are fully sealed and very robust.

### FI SERIES flow ranges and options

Flow lpm	Max Pressure bar	Option			
		Fluid		Material	
		Oil	Water	Aluminium	Bronze
16	420	*	-	*	*
30	420	*	*	*	*
60	420	*	*	*	*
120	420	*	*	*	*
180	420	*	-	*	*
200	350	*	*	*	*
300	350	*	-	*	*
400	350	*	*	*	*

For further information on FI and WP flow indicators refer to the following page \* Options available.

### OPERATION FI SERIES

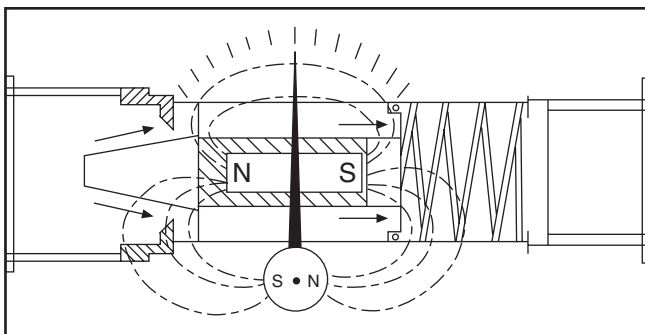

Section drawing of FI 750 Flow Indicator

The flow indicator consists of a sharp edged orifice and tapered metering piston which moves in proportion to changes in flow rate.

In the no flow condition the metering piston is at the minimum orifice position and the pointer indicates zero. With increasing flow the pressure difference across the variable orifice, (formed by the metering piston and fixed orifice), moves the piston against a calibrated spring. The piston movement is directly proportional to flow rate and the sharp edge orifice minimises the effects of viscosity.

The piston is magnetically coupled to the rotary pointer assembly which registers on a clear 63mm (2 1/2") diameter scale, calibrated in lpm and gpm.

# INSTALLATION

The Webster flow indicators can be installed directly in a high pressure or return line. Mounting position of the Flow Indicator is not critical, they can be used at any angle. However, for the best accuracy, they should be mounted horizontally.

The FI series indicators can be panel mounted on the front face. But, any ferrous metal should be more than 19 mm (3/4") away from the rear and bottom faces of the flow block. Pressure gauges may be mounted directly into the block.

Consult Sales office for gauge adaptors and pressure test points for the FI series flow indicators

## Models FI 750

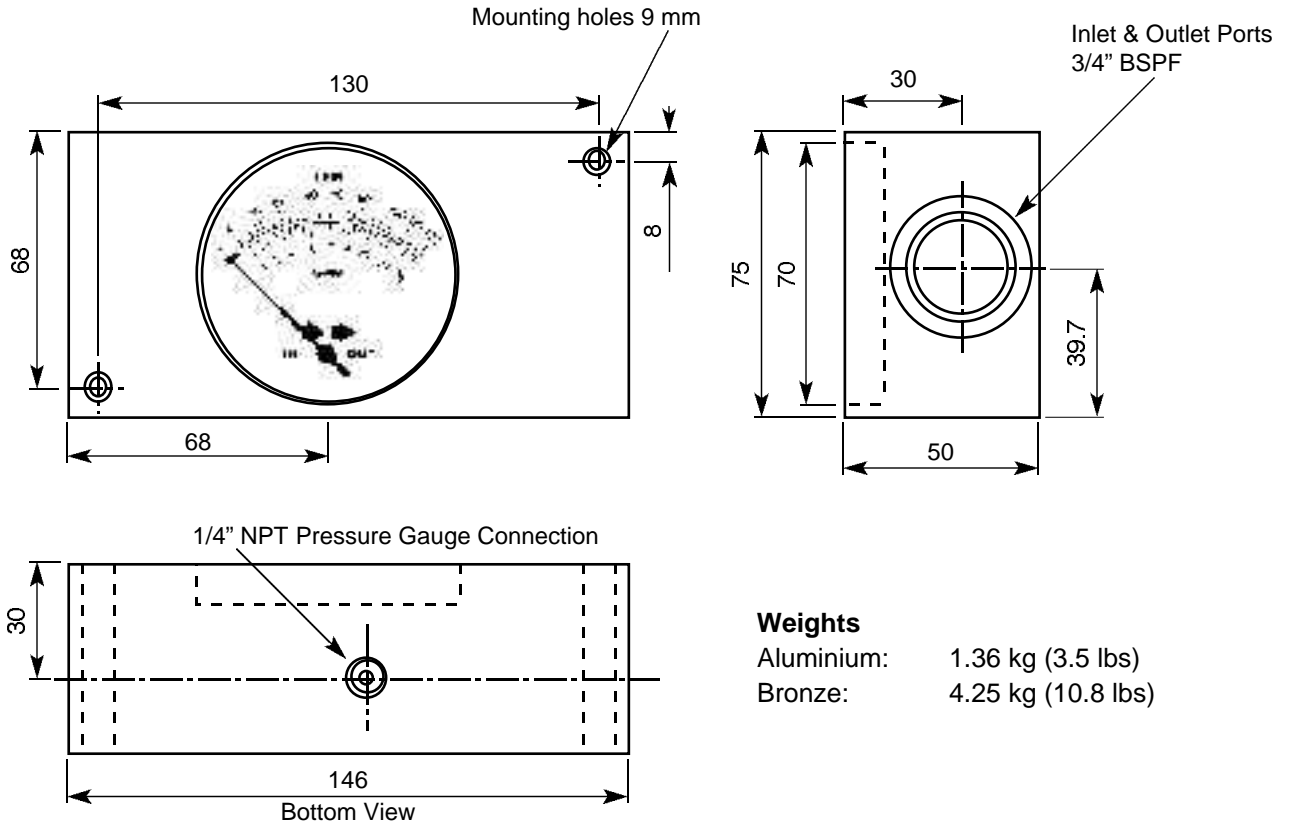

**Weights**  
 Aluminium: 1.36 kg (3.5 lbs)  
 Bronze: 4.25 kg (10.8 lbs)

## Models FI 1500

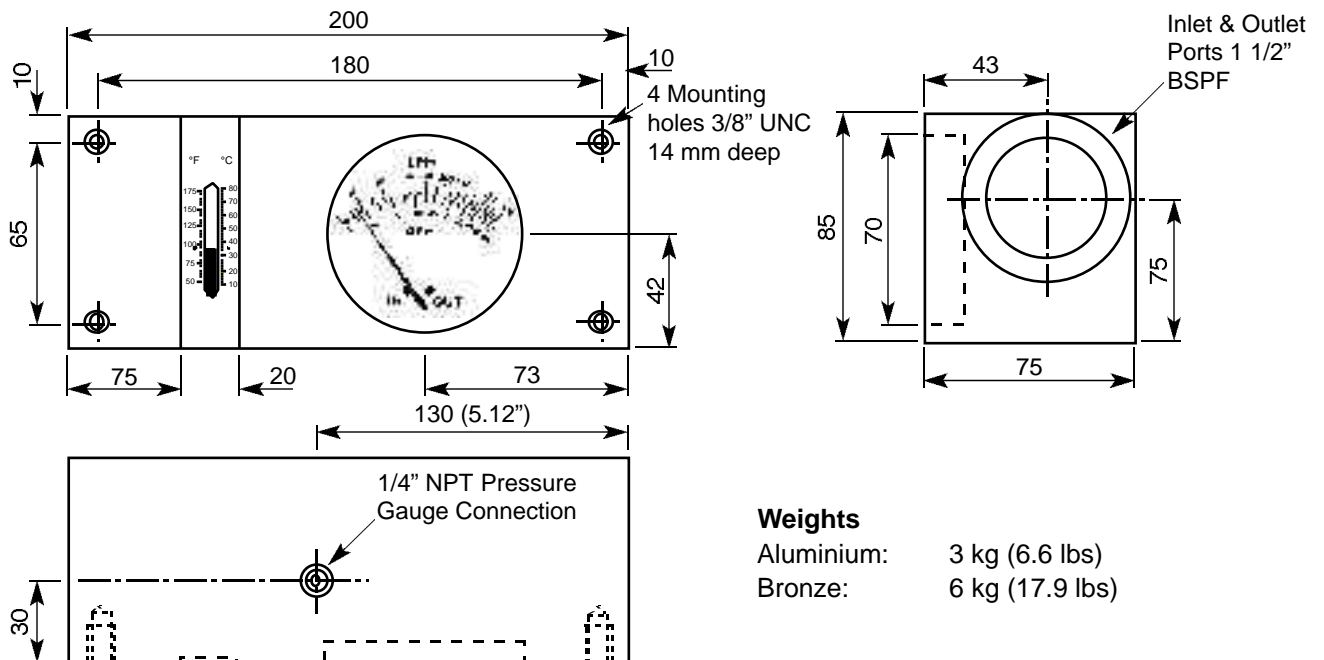

**Weights**  
 Aluminium: 3 kg (6.6 lbs)  
 Bronze: 6 kg (17.9 lbs)

# Low Cost In-Line Flow Indicator with built in Thermometer

- 16 lpm
- 30 lpm
- 60 lpm
- 120 lpm
- 180 lpm
  
- Up to 420 bar

Flow Indicators are designed for continuous monitoring or intermittent use commissioning and servicing hydraulic systems up to 420 bar, 6000 psi.

The large clear 63mm diameter dial ensures that quick checks can be made to determine pump performance and setting of flow control valves. They can be used on mobile and industrial hydraulic circuits. Also lubrication and coolant systems using oil/water.

These direct acting flow indicators can be installed in hazardous areas or on applications where no power is available. The flow indicator design ensures good reliability and minimises the effects of contamination.

## Operation

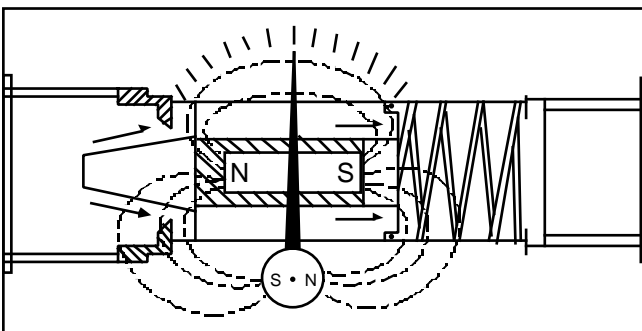

Section drawing of FI 750 Flow Indicator

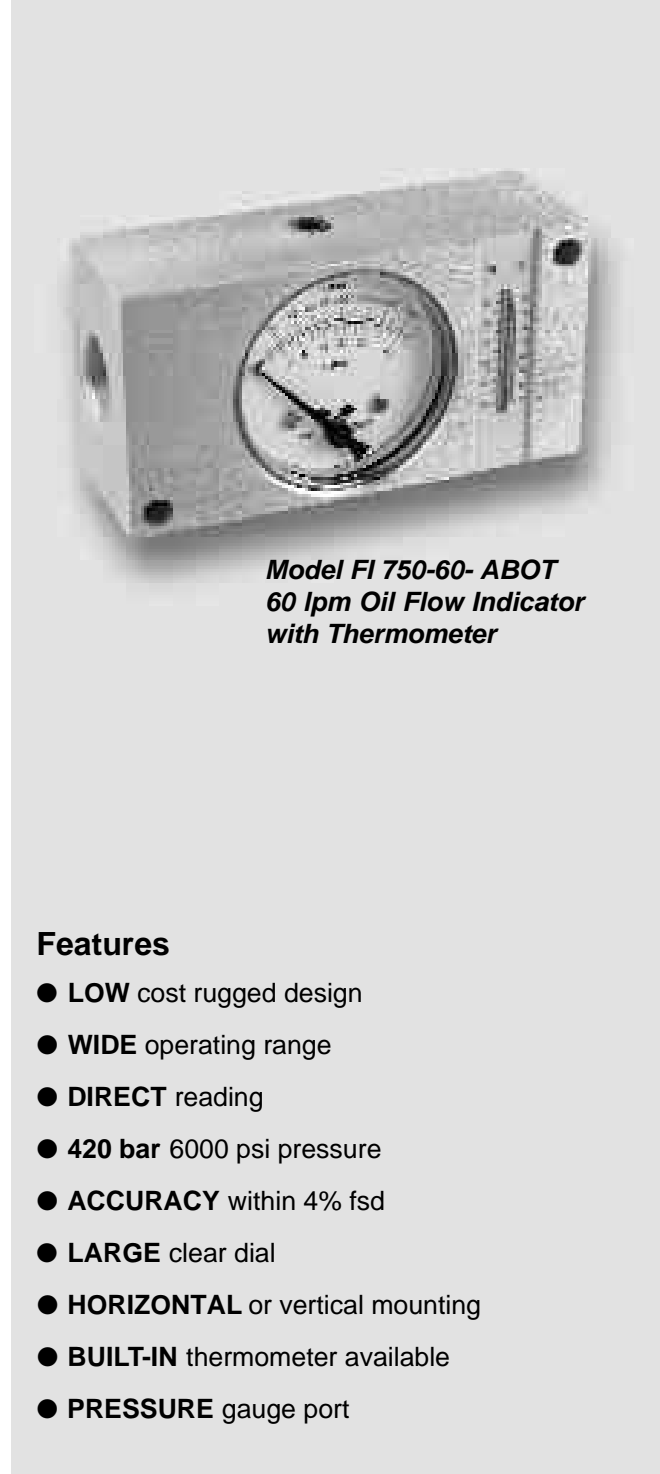

*Model FI 750-60- ABOT  
60 lpm Oil Flow Indicator  
with Thermometer*

## Features

- **LOW** cost rugged design
- **WIDE** operating range
- **DIRECT** reading
- **420 bar** 6000 psi pressure
- **ACCURACY** within 4% fsd
- **LARGE** clear dial
- **HORIZONTAL** or vertical mounting
- **BUILT-IN** thermometer available
- **PRESSURE** gauge port

The flow indicator consists of a sharp edged orifice and tapered metering piston.

The piston movement is directly proportional to flow rate and the sharp edge orifice minimises the effects of viscosity. The piston is magnetically coupled to the rotary pointer assembly which registers on a clear 63mm ( 2 1/2" ) scale calibrated in lpm and gpm.

The FI750 flow indicators should not be installed in circuits where the flow is reversed.

**See RFI series for reversible operation.**

## Specifications

Model No. With thermometer	Model No. Without thermometer	Fluid	Body Material	Flow		Weight Kg
				lpm	gpm	
FI 750 - 16 ABOT	FI 750 - 16 ABO	Oil	Aluminium	1 - 16	0.25 - 3.5	1.36
FI 750 - 30 ABOT	FI 750 - 30 ABO	Oil	Aluminium	2 - 30	0.50 - 7.0	1.36
FI 750 - 60 ABOT	FI 750 - 60 ABO	Oil	Aluminium	3 - 60	0.80 - 14.0	1.36
FI 750 - 120 ABOT	FI 750 - 120 ABO	Oil	Aluminium	5 - 120	1.20 - 26.0	1.36
FI 750 - 180 ABOT	FI 750 - 180 ABO	Oil	Aluminium	8 - 180	2.00 - 40.0	1.36
FI 750 - 16 BBOT	FI 750 - 16 BBO	Oil	Bronze	1 - 16	0.25 - 3.5	4.25
FI 750 - 30 BBOT	FI 750 - 30 BBO	Oil	Bronze	2 - 30	0.50 - 7.0	4.25
FI 750 - 60 BBOT	FI 750 - 60 BBO	Oil	Bronze	3 - 60	0.80 - 14.0	4.25
FI 750 - 120 BBOT	FI 750 - 120 BBO	Oil	Bronze	5 - 120	1.20 - 26.0	4.25
FI 750 - 180 BBOT	FI 750 - 180 BBO	Oil	Bronze	8 - 180	2.00 - 40.0	4.25

Pressure 420 bar, 6000 psi

## Connections

By flexible hoses or steel pipes. Inlet and Outlet ports 3/4" BSPF.

## Measurement and Indication

### Flow

Measured by a tapered metering piston moving within a fixed, sharp edged orifice, designed to minimise the effects of changes in temperature and viscosity. A pressure drop occurs across the variable orifice and the piston movement is proportional to the change in flow rate.

**Accuracy:** ± 4% of full flow.

### Temperature

Indicated in °C and °F by an optional thermometer set in rubber compound and built into the flow block to sense temperature changes in the fluid passage.

**Accuracy:** ± 2 °C.

Range: 10 - 80°C, 50 - 180 °F

Consult sales office for flow indicators suitable for higher working temperatures.

## Construction

### Flow Block

The solid high tensile aluminium or bronze block houses a metering piston. The piston is magnetically coupled to a rotary pointer to provide a direct reading of flow on a clear 63mm (2 1/2") diameter flow scale

calibrated in lpm and gpm. Both flow and temperature scales are shielded behind impact resistant windows. The whole unit is fully sealed and very strong.

## General

### Pressure Accessories

Optional 63mm diameter glycerine filled pressure gauge fitted directly into a 1/4" NPT connection in the block or remotely connected by micro bore hose.

**Accuracy:** ± 1.6% of full scale.

### Accessory Chart

Pressure Range		Direct Gauge	Remote Gauge Kit
bar	psi		
70	1,000	FT 6160 - 1	FT 5987 - 1
210	3,000	FT 6160 - 2	FT 5987 - 2
280	4,000	FT 6160 - 3	FT 5987 - 3
420	6,000	FT 6160 - 4	FT 5987 - 4

### Other Applications

Units suitable for Mining, Offshore and High Pressure Water applications are available. See bulletin FI 3E and FIK 1 E for bronze models and indicators with loading valves.

### How to Order

Specify flow indicator from table detailing material and thermometer pressure gauge options. FI 750 - 180 ABOT with FT 5987 - 4 is a 180 lpm Aluminium flow indicator with temperature and remote 6,000 psi pressure gauge kit.

## Performance

Typical pressure drop curves. Oil viscosity 25 centistokes.

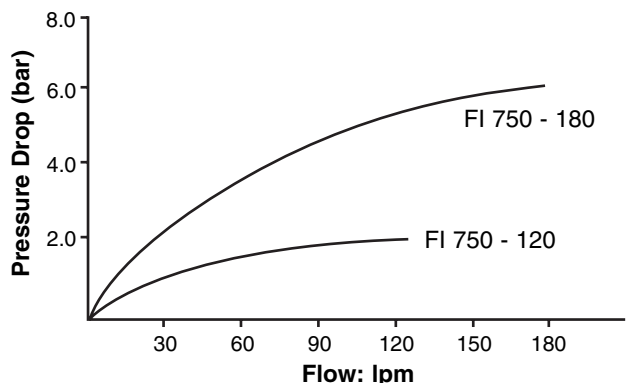
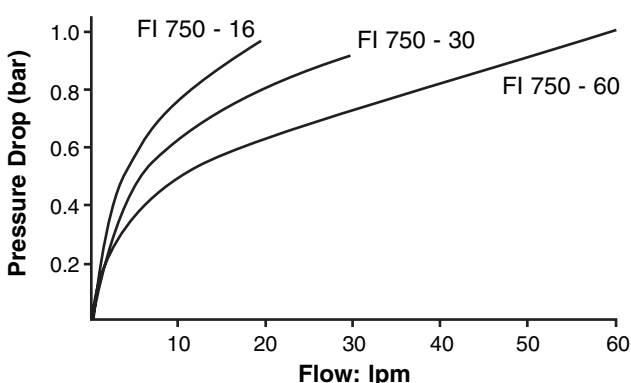

# Low Cost In-Line Flow Indicator with built in Thermometer for Water or Oil

- 30 lpm
- 60 lpm
- 120 lpm
- 200 lpm
- 400 lpm
- Up to 420 bar

Flow Indicators are designed for continuous monitoring or intermittent use commissioning and servicing hydraulic systems up to 420 bar, 6000 psi (FI 750) or 350 bar, 5000 psi (FI 1500)

The large clear 63mm diameter dial ensures that quick checks can be made to determine pump performance and setting of flow control valves. They can be used on cooling systems, hydraulic machinery and mining equipment using water and water-oil emulsions.

These direct acting flow indicators can be installed in hazardous areas or on applications where no power is available. The flow indicator design ensures good reliability and is tolerant to contamination.

## Operation

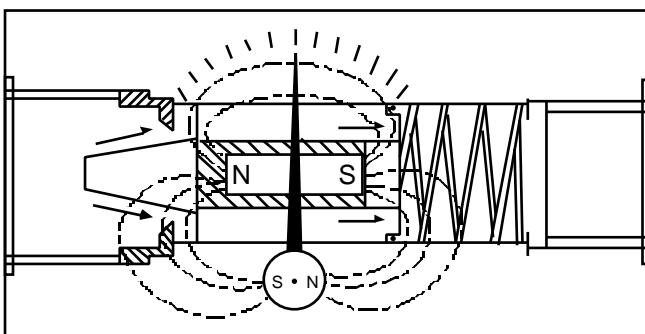

Section drawing of FI 750 Flow Indicator



*Model FI 750-120-BBWT  
Water / Oil Flow Indicator  
with thermometer*

## Features

- **LOW** cost rugged design
- **WIDE** operating range
- **DIRECT** reading
- **HIGH** Pressure applications
- **ACCURACY** within 4% fsd
- **LARGE** clear easy to read dial, dual scale
- **HORIZONTAL** or vertical mounting
- **BUILT-IN** thermometer available
- **PRESSURE** gauge port

The flow indicator consists of a sharp edged orifice and tapered metering piston.

The piston movement is directly proportional to flow rate and the sharp edged orifice minimises the effects of viscosity. The piston is magnetically coupled to the rotary pointer assembly which registers on a clear 63mm (2 1/2") scale calibrated in lpm for water and oil.

The FI750 flow indicators should not be installed in circuits where the flow is reversed.

**See RFI series for reversible operation.**

## Specifications

Model No. without Thermometer	Model No. with Thermometer	Body Material	Flow Range		Max. Working Pressure		Temperature Range	
			lpm		psi		°C	
			Water	Oil	bar	°F		
FI 750 - 30 BBW	FI 750 - 30 BBWT	Bronze	2 - 35	2 - 30	6000	420	10 - 80	50 - 180
FI 750 - 60 BBW	FI 750 - 60 BBWT	Bronze	3 - 70	3 - 60	6000	420	10 - 80	50 - 180
FI 750 - 120 BBW	FI 750 - 120 BBWT	Bronze	5 - 140	5 - 120	6000	420	10 - 80	50 - 180
FI 1500 - 200 BBW	FI 1500 - 200 BBWT	Bronze	10 - 200	10 - 200	5000	350	10 - 80	50 - 180
FI 1500 - 400 BBW	FI 1500 - 400 BBWT	Bronze	40 - 400	30 - 400	5000	350	10 - 80	50 - 180

## Connections

By flexible hoses or steel pipes. Inlet and Outlet ports **FI 750:** 3/4" BSPF. **FI 1500:** 1 1/2" BSPF

## Measurement and Indication

### Flow

Flow is measured by a tapered metering piston moving within a fixed, sharp edged orifice, designed to minimise the effects of changes in temperature and viscosity. The pressure drop across the variable orifice causes the piston to move and is proportional to the change in flow rate.

**Accuracy:** ± 4% of full flow

### Temperature

Temperature is indicated in °C and °F by a thermometer set in rubber compound and built into the flow block to sense temperature changes in the fluid passage.

**Accuracy:** ± 2 °C.

## Construction

### Flow Block

The solid high strength bronze block houses a metering piston. The piston is magnetically coupled to a rotary pointer to provide a direct reading of flow on a clear 63mm (2 1/2") diameter flow scale calibrated in lpm. Both flow and temperature scales are shielded behind impact resistant polycarbonate windows. The bronze flow indicator is aluminium free and is fully sealed externally.

### Loading Valve for Oil or Water/Oil Emulsion

Loading valves with **Internal** safety discs provide progressive control of system pressure during flow and pressure checks.

Consult Sales Office

### Dimension / Weights

FI 750	146 x 75 x 50mm	3.8 kg
FI 1500	200 x 85 x 75mm	8 kg

## General

### Pressure Accessories

Optional 63mm diameter glycerine filled pressure gauge can be fitted directly into a 1/4" NPT connection in the block or remotely connected by micro-bore hose.

**Accuracy:** ± 1.6% of full scale.

### Applications

Webster flow indicators are designed for continuous monitoring on mining, offshore and high pressure water applications.

### How to Order

Specify flow indicator from table. FI 750-60 BBWT is a 60 lpm bronze flow indicator with thermometer. Consult Sales Office for details of optional pressure gauges.

## Installation

The indicator can be connected into pressure or return lines, however, do not reverse flow. The indicator will not be damaged but will act as a non return valve.

## Performance

Typical pressure drop curves. Oil viscosity 25 centistokes.

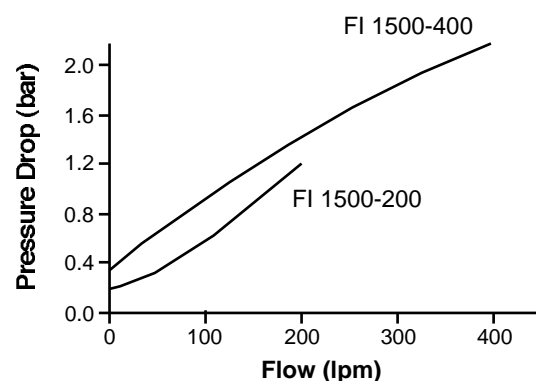
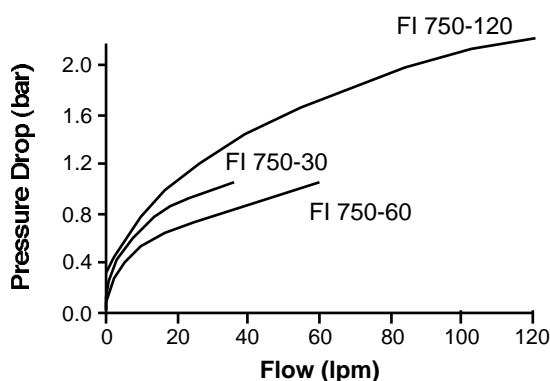

## In-Line Flow Indicator with built in Thermometer

- 200 lpm
- 300 lpm
- 400 lpm
  
- Up to 350 bar

The Webster In-Line Flow Indicator comprises a variable orifice flow meter with built in thermometer and optional pressure gauge.

The flow indicator provides the ideal solution for continuous or intermittent monitoring of hydraulic systems up to pressures of 350 bar; 5000 psi.

The large clear 63mm diameter dial ensures that quick checks can be made to determine pump performance and setting of flow control valves. It can be used on mobile and industrial hydraulic circuits and also on lubrication and coolant systems using oil, water or oil/water emulsions. (Bronze flow indicators are available calibrated for water).

The direct acting flow indicators can be installed in hazardous areas or on applications where no electrical power is available. The flow indicator design ensures good reliability and is tolerant to contamination.

For external protection the readout scales of both thermometers and flow indicator are recessed and shielded behind impact resistant windows. The whole unit is fully sealed and mechanically robust. Aluminium free flow indicators for Mining and Offshore applications are available

### Operation

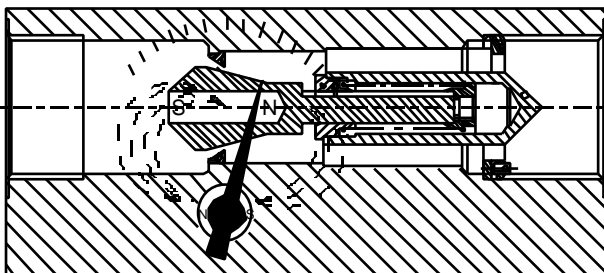

Section drawing of FI 1500 Flow Indicator

The flow indicator consists of a sharp edged orifice and tapered metering piston.

The piston movement is directly proportional to flow rate and the sharp edge orifice minimises the effects of viscosity. The piston is magnetically coupled to the rotary pointer assembly which registers on a clear 63mm ( 2 1/2" ) scale calibrated in lpm and gpm.

The FI750 flow indicators should not be installed in circuits where the flow is reversed.

**See RFI series for reversible operation.**

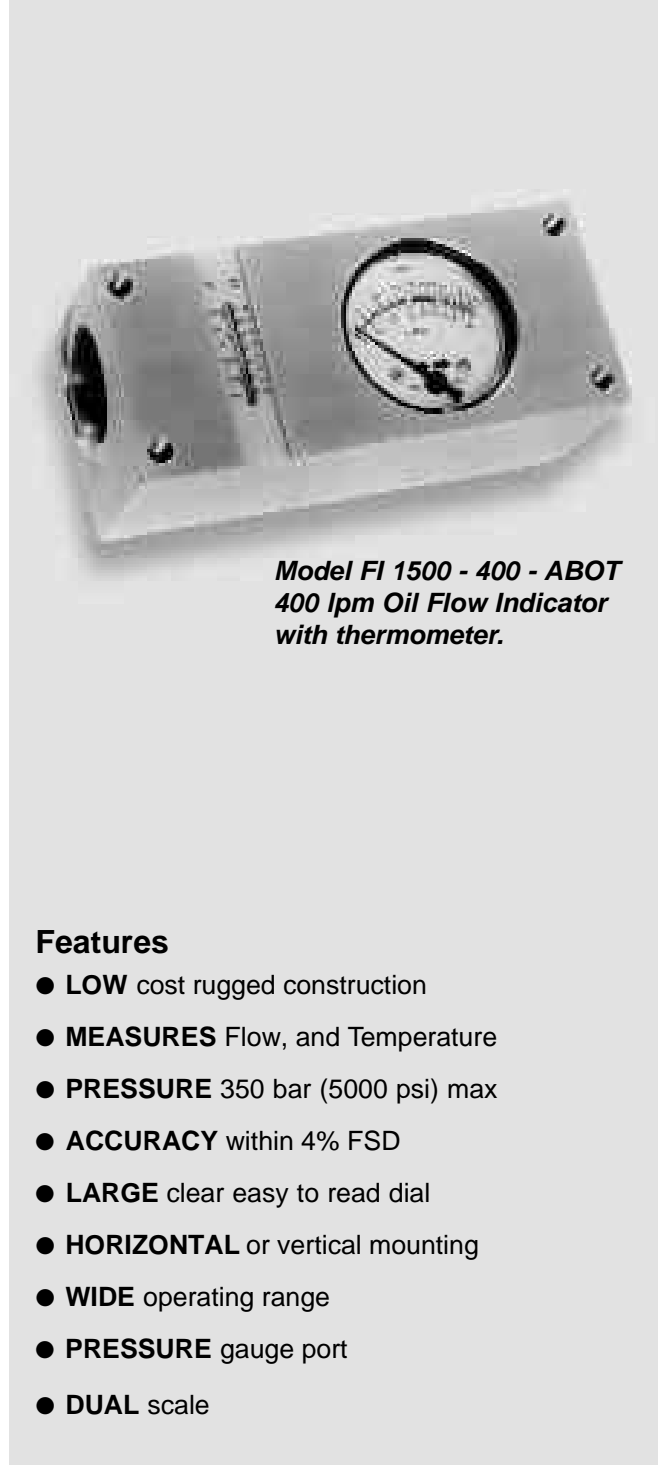

*Model FI 1500 - 400 - ABOT  
400 lpm Oil Flow Indicator  
with thermometer.*

### Features

- **LOW** cost rugged construction
- **MEASURES** Flow, and Temperature
- **PRESSURE** 350 bar (5000 psi) max
- **ACCURACY** within 4% FSD
- **LARGE** clear easy to read dial
- **HORIZONTAL** or vertical mounting
- **WIDE** operating range
- **PRESSURE** gauge port
- **DUAL** scale

## Specifications

Model No. Aluminium	Model No. Bronze	Flow Range		Max Working Pressure		Temperature Range	
		lpm	gpm	bar	psi	°C	°F
FI 1500 - 200 ABOT	FI 1500 - 200 BBOT	8 - 200	2 - 44	350	5000	10 - 80	50 - 180
FI 1500 - 300 ABOT	FI 1500 - 300 BBOT	10 - 300	2 - 66	350	5000	10 - 80	50 - 180
FI 1500 - 400 ABOT	FI 1500 - 400 BBOT	15 - 400	4 - 90	350	5000	10 - 80	50 - 180

## Connections

By flexible hoses or steel pipes. Inlet and Outlet ports 1 1/2" BSPF.

## Measurement and Indication

### Flow

Flow is measured by a tapered metering piston moving within a fixed, sharp edged orifice, designed to minimise the effects of changes in temperature and viscosity. The fluid flow causes a pressure drop across the variable orifice and the piston movement is proportional to the change in flow rate.

**Accuracy:** ± 4% of full flow.

### Temperature

Indicated in °C and °F by a thermometer set in rubber compound and built into the flow block to sense temperature changes in the fluid passage.

**Accuracy:** ± 2°C.

## Construction

### Flow Block

Solid high tensile aluminium or bronze block houses a metering piston which moves against a calibrated spring. The piston is magnetically coupled to a rotary pointer to provide a direct reading of flow on a clear 63mm (2 1/2") diameter flow scale calibrated in lpm and gpm. Both flow and temperature scales are shielded behind impact resistant windows. The whole unit is fully sealed and mechanically robust.

### Dimensions

200 x 85 x 75mm (7.87 x 3.35 x 2.95 inches)

Aluminium 3.2 Kg, 7 lbs

Bronze 9.2 Kg, 20.24 lbs

## General

### Pressure

Optional 63mm diameter glycerine filled pressure gauge fitted directly into a 1/4" NPT port in the block or remotely connected by pressure test point.

**Accuracy:** ± 1.6% of full scale

See pressure gauge bulletin for more details.

### Accessories

Loading valves, with **Internal** safety disc.

Pressure gauge.

Pressure gauge test adaptors.

### How to Order

Specify flow indicator from table above detailing material. FI 1500-400 ABOT is a 400 lpm Aluminium flow indicator with thermometer.

## Installation

The Indicator can be connected into pressure or return lines, however, the flow indicator is uni-directional and **closes** with reverse flow.

## Performance

Typical pressure drop curves. Oil viscosity 25 centistokes.

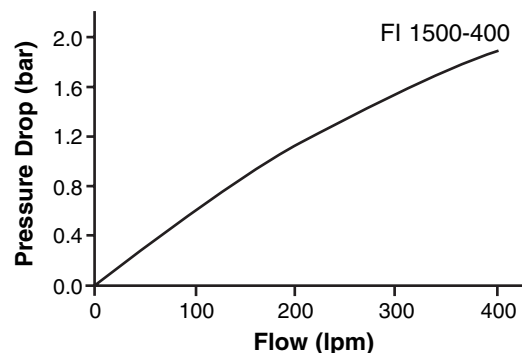
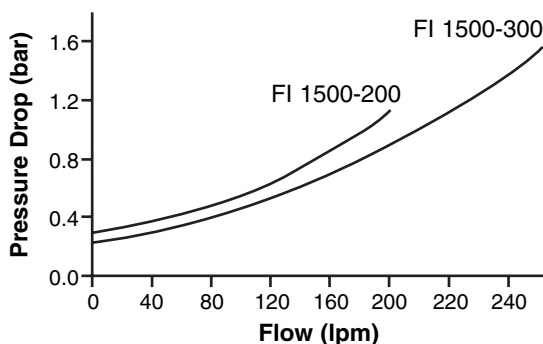

# RFI Reversible Flow Indicator with built in Thermometer

- 120 lpm
- 180 lpm
  
- Up to 420 bar

The RFI reversible flow indicator is designed for continuous monitoring or intermittent use commissioning and servicing hydraulic systems up to 420 bar, 6000 psi.

The large 63 mm diameter dial ensures that quick checks can be made to determine pump performance and setting of flow control valves. They can be used anywhere on mobile and industrial hydraulic circuits to test pumps, motors, valves and cylinders.

These direct acting flow indicators can be installed in hazardous areas or on applications where no power is available. The flow indicator design ensures good reliability and minimises the effects of contamination.

## Operation

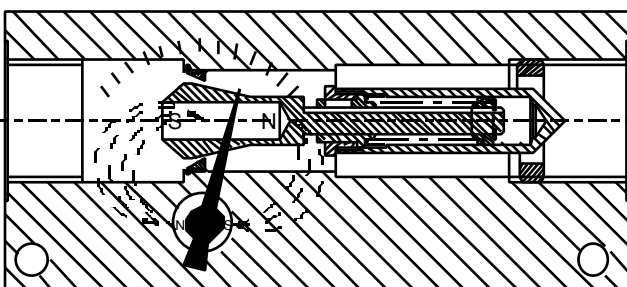

*Section drawing of the RFI Flow Indicator*

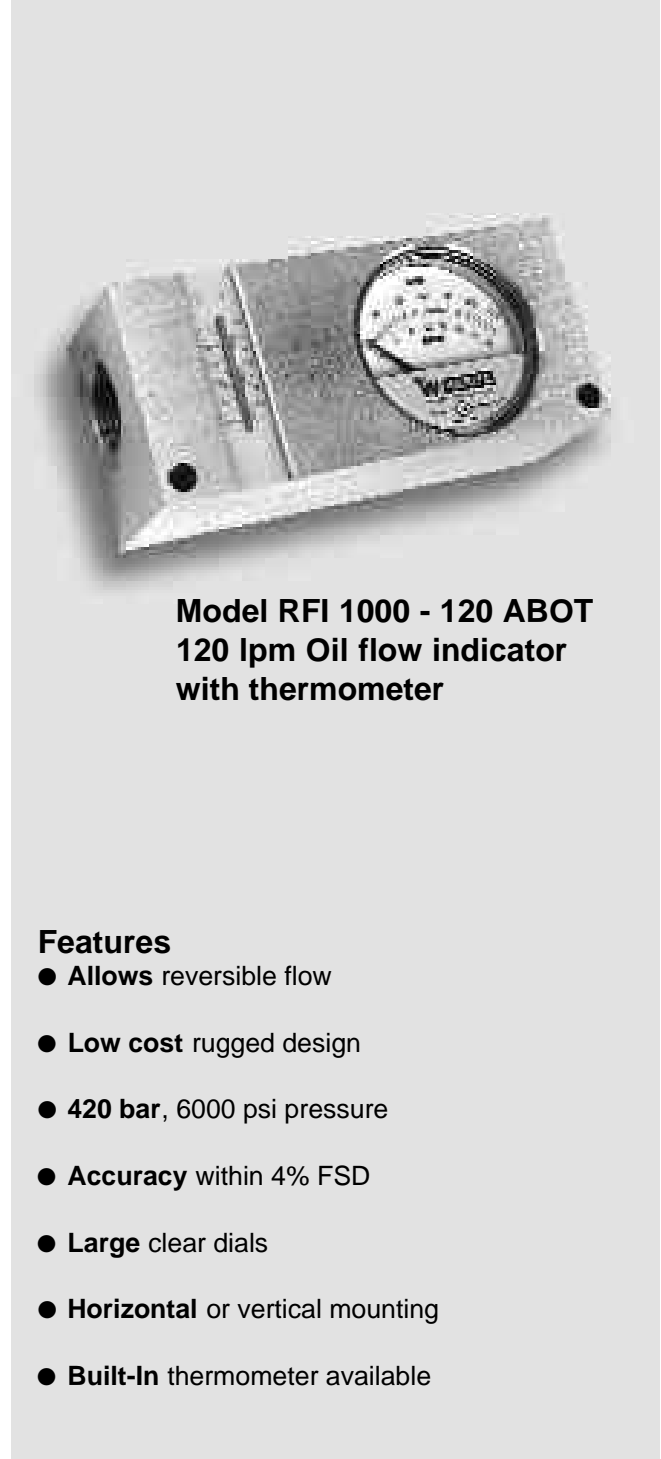

**Model RFI 1000 - 120 ABOT  
120 lpm Oil flow indicator  
with thermometer**

## Features

- **Allows** reversible flow
- **Low cost** rugged design
- **420 bar**, 6000 psi pressure
- **Accuracy** within 4% FSD
- **Large** clear dials
- **Horizontal** or vertical mounting
- **Built-In** thermometer available

The flow indicator consists of a sharp edged orifice and tapered metering piston.

The piston movement is directly proportional to flow rate and the sharp edge orifice minimises the effects of viscosity. In reverse the piston moves back to allow the flow to return at low pressure. The piston is magnetically coupled to the rotary pointer assembly which registers on a clear 63 mm (2 1/2") scale calibrated in lpm and gpm. The RFI flow indicators are reversible and may be mounted in cylinder and motor circuits,

## Specification

Model No. with thermometer	Model No. without thermometer	Fluid	Body Material	Flow Range		Weight (kg)
				lpm	gpm (US)	
RFI 1000 - 120 ABOT	RFI 1000 - 120 ABO	Oil	Aluminium	5 - 120	1.3 - 32	2
RFI 1000 - 180 ABOT	RFI 1000 - 180 ABO	Oil	Aluminium	8 - 180	2.1 - 48	2

Max. Pressure: 420 bar, 6000 psi

### Connections

By flexible hoses or steel pipes. Inlet and outlet ports are 1" BSPF.

### Adaptors

Adaptor Fitting Kit comprising 6 male-male adaptors and 2 bonded seals to provide 1" BSPF, 3/4" BSPF, 1/2" BSPF, male connectors.

## Measurement and Indication

### Flow

Flow is measured by a tapered metering piston moving within a fixed, sharp edged orifice designed to minimise the effects of changes in temperature and viscosity. A pressure drop occurs across the variable orifice and the piston movement is proportional to the change in flow rate. In reverse the piston moves back to allow the flow to return at low pressure.

**Accuracy:**  $\pm 4\%$  of full flow.

### Pressure Drop (in both flow directions)

RFI 1000 - 120 ABOT 1.4 bar

RFI 1000 - 180 ABOT 2.8 bar

At full flow with oil viscosity of 28 centistokes

### Temperature

Indicated in °C and °F by an optional thermometer set in rubber compound and built into the flow block to sense temperature changes in fluid passage.

**Accuracy:**  $\pm 2$  °C.

Range: 10 - 80 °C , 50 - 180 °F

Consult Sales Office for flow indicators suitable for higher working temperatures.

## Construction

### Flow Block

The solid high tensile aluminium block houses a metering piston. The piston is magnetically coupled to a rotary pointer to provide a direct reading of flow on a clear 63mm (2 1/2") diameter flow scale calibrated in lpm or gpm. Both flow and temperature scales are shielded behind impact resistant windows. The whole unit is fully sealed and very strong.

### Loading Valve (Optional)

The HV100 loading valve is connected directly to the flow block. The valve is easy to operate and allows progressive control of system pressure.

See Bulletin RFIK 1E flow test kit for details.

### Accessories

#### Pressure Gauge

Optional 63mm diameter glycerine filled pressure gauge, accuracy 1.6% FSD, is fitted into a 1/4 NPT connection in the block or remotely connected by using a test point.

### Other Applications

Units suitable for Mining, Offshore and High Pressure Water applications are available.

See Bulletin FI 3E for details.

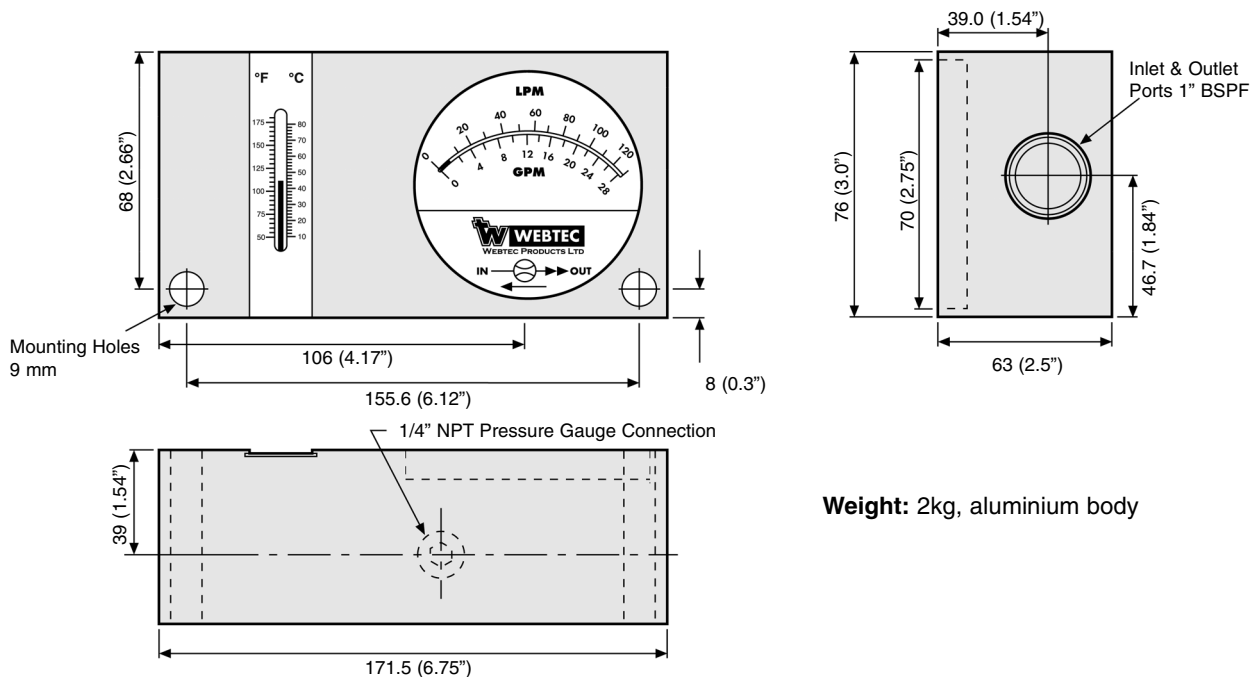

**Weight:** 2kg, aluminium body

### How to order

Specify flow indicator from table detailing thermometer and pressure gauge options. RFI 1000 - 120 ABOT is a 120 lpm Aluminium flow indicator with thermometer.

# In-Line Flow Indicator with Electrical Switch

- 16 lpm
- 30 lpm
- 60 lpm
- 120 lpm
- 180 lpm
  
- Up to 420 bar

Webster Flow Switches are designed for continuous monitoring of Systems up to 420 bar, 6000 psi and flows from 4 to 180 lpm. These direct acting flow switches can be installed in pressure or return lines.

The switch can be used for any application where the flow must be controlled within certain limits and where a remote warning is required. A typical application could be giving WARNING of low flow for bearing lubrication or cooling water used in injection moulding and die casting machines.

The switch is fully adjustable and can also be set to operate if high flow is demanded on hydraulic ring main circuits. An optional thermometer is set in rubber compound and angled deep in the block to sense the temperature changes in the fluid passage. The dials are clear and easy to read. The whole unit is sealed and extremely rugged.



## Features

- **LOW** cost rugged design
- **Oil or Water** 1 - 180 lpm  
Consult Sales Office for switches up to 400 lpm
- **DIRECT** reading
- **420 bar** 6000 psi pressure
- **LARGE** easy to read dial
- **ACCURACY** better than 4% FSD
- **SWITCH** repeatability better than 2% FSD
- **EASY** switch adjustment
- **THERMOMETER** 80 °C 180 °F
- **SWITCH** rating 0.5 Amps - 90 V DC Max  
0.5 Amps- 50VAC Max  
5 watts AC or DC  
Consult Sales Office for higher switch rating.
- **WIDE** operating range.
- **PRESSURE** gauge port standard

# Flow Switch for FI Series Flow Indicators

## Operation

The flow switch incorporates a magnetic reed switch which is opened and closed by the magnetic field of the flowmeter piston.

The switch can be set for normally open or closed depending on the position of the flow switch. It can be adjusted to the required flow setting, as shown on the flowmeter dial

## Wiring

The switch is single pole and wired in series as shown. Please note inductive loads are not recommended. Consult your Sales Office for flow switches 200 - 400 lpm, FI 1500 Series.

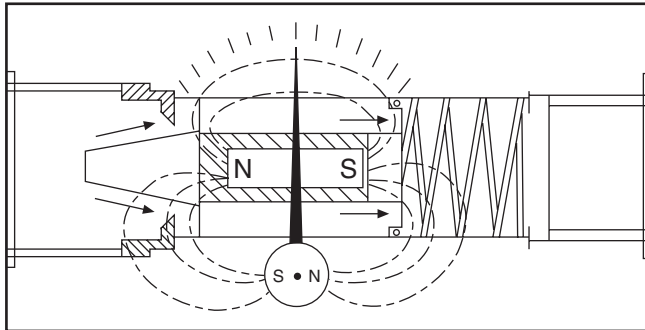
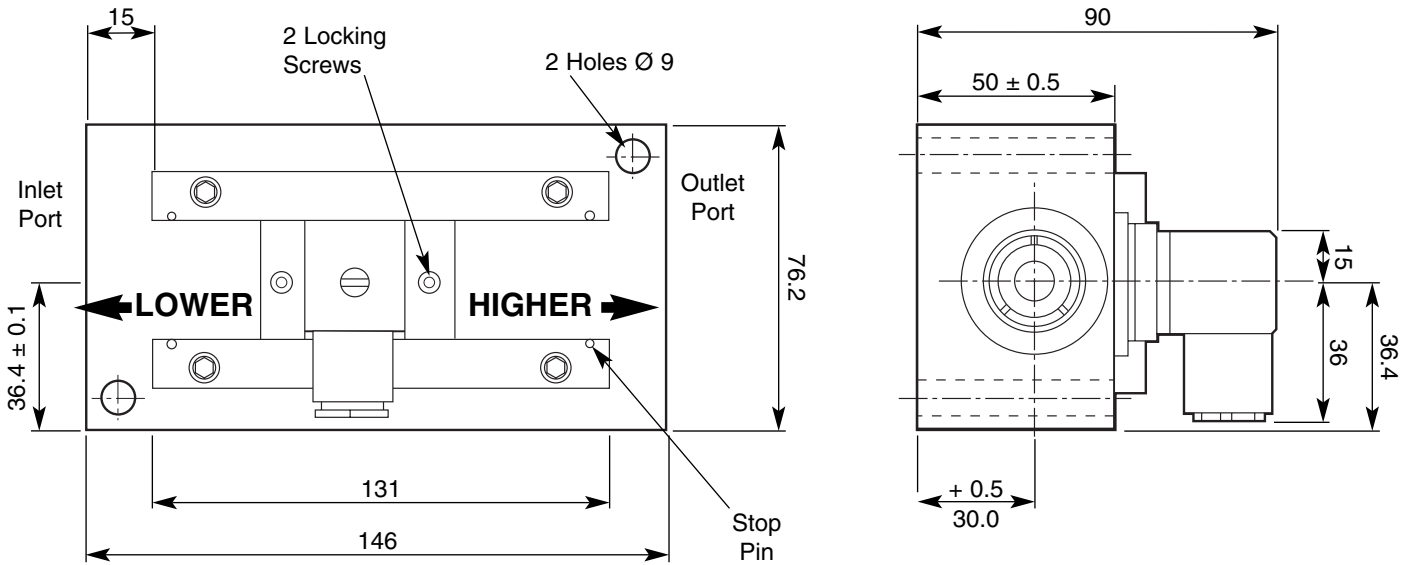
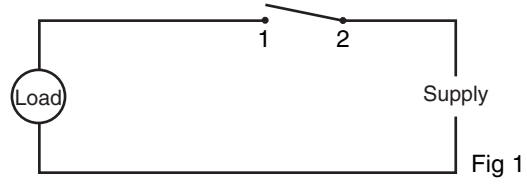

The flow indicator consists of a sharp edged orifice and tapered metering piston which moves in proportion to changes in flow rate.

In the no flow condition the metering piston is at the minimum orifice position and the pointer indicates zero. With increasing flow the pressure difference across the variable orifice, (formed by the metering piston and fixed orifice), moves the piston against a calibrated spring. The piston movement is directly proportional to flow rate and the sharp edge orifice minimises the effects of viscosity.

The piston is magnetically coupled to the rotary pointer assembly which registers on a clear 63mm (2 1/2") diameter scale, calibrated in lpm and gpm.

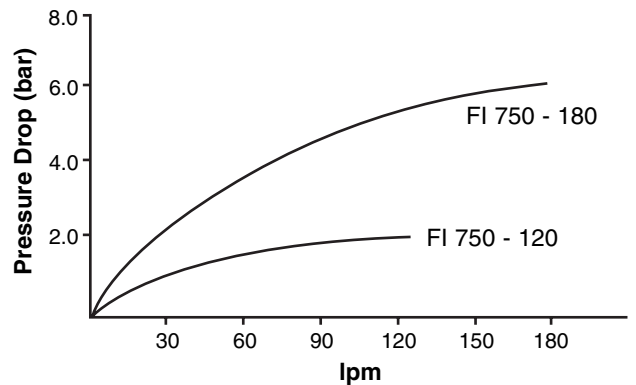
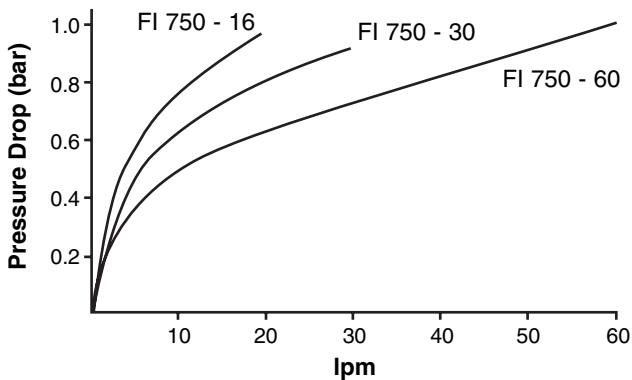

## How to order

Select the flow indicator for oil or water as shown on page 4 and 6. Specify the optional switch and required flow settings.

## WP Series Hydraulic Flow Monitor

- Flow rates from 0.5 to 550 lpm
- Select from aluminium, brass or stainless steel

The WP series in-line flow monitors are designed for continuous monitoring or intermittent use for troubleshooting or commissioning industrial or mobile hydraulic systems up to 240 bar.

The tubular scale is easily read through the clear polycarbonate window and ensures checks can be made to determine pump performance and setting of flow control valves. The unit is fully sealed for weather tight or wash down applications. An optional Pyrex safety glass window is available.

Wetted seals are available in Buna (standard), Viton®, EPR or Kalrez®, so compatibility with hydraulic fluids in mobile, industrial or other applications such as lubrication or coolant systems is not a problem.

The WP series flow monitors do not require straight inlet or outlet piping or require vertical installation. The advanced design of the sharp edged orifice ensures good reliability over a wide viscosity range and minimises the effect of contamination. Accuracy is 2.5% over the centre third of the scale and 4% over the entire flow range.



### Features

- Low cost solution
- Wide variety of flow ranges, 0.5 - 550 lpm
- Accurate within 2.5% over mid-scale, 4% FSD
- Choice of aluminium, brass & stainless steel
- Pressure rating to 240 bar (420 bar stainless steel)
- Excellent viscosity stability to a min of 95 cSt
- Port sizes from 1/4" to 2"
- Ports available in BSP
- Direct reading, dual calibration, lpm & US gpm
- Aluminium construction
- Advanced stainless steel sharp edge orifice
- Unrestricted mounting in any orientation

## Specification

### Measuring accuracy

± 2.5% of full-scale in the centre third of the measuring range  
± 4% of full-scale over the entire scale range

### Repeatability

± 1% of full scale

### Flow measuring range

0.5 - 550 lpm

### Maximum operating pressure

Aluminium and Brass monitors 240 bar, stainless steel 420 bar

### Maximum operating temperature

115° C

Note: For operation to 315° C, a high temperature range is available

### Pressure differential

See graphs below

### Standard calibration fluids

Oil monitors: DTE 25 @ 43°C (40 cSt), 0.873 sg  
Water monitors: Tap water @ 21°C (1 cSt), 1.0 sg

## Pressure differential graphs categorised by size code

Series 3 (1/4" - 1/2")

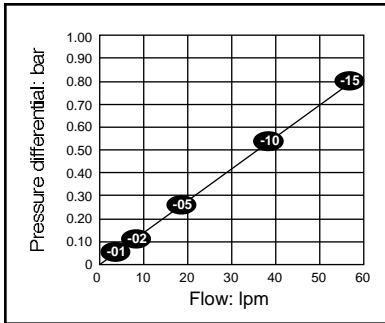

Series 4 (3/4" - 1")

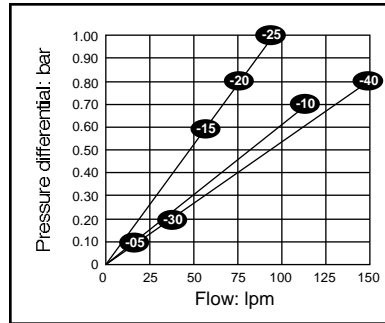

Series 5 (1 1/4" - 2")

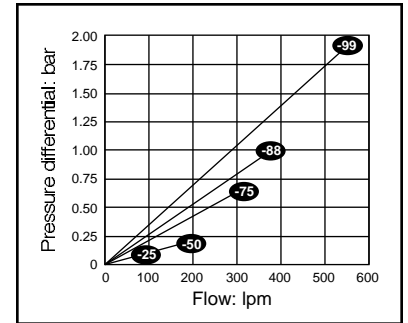

15 = Model number (see Sales Brochure)

## Construction

### Wetted components:

High pressure casing, end ports and tapered shafts: *Aluminium, Brass and Stainless Steel*

Seals: *Buna-N (STD), EPR, Viton® or Kalrez®*

Transfer magnet: *Teflon® coated Alnico*

Floating Orifice disc: *Stainless Steel*

All other internal parts: *Stainless Steel*

### Non-wetted components:

Window tube: *Polycarbonate (STD), Pyrex*

Window seals: *Buna-N (STD), Teflon®*

*(Teflon® is a registered trademark of DuPont)  
(Viton® & Kalrez® are registered trademarks of Dow DuPont Elastomers)*

## Dimensions

### Dimensions and porting options

Size code	2	3	4	5	5*			
Dim. A (mm)	32	48	60	90	90			
Dim. B (mm)	122	167	182	258	322			
Port sizes (inch BSP)	1/4"	3/8"	1/2"	3/4"	1"	1 1/4"	1 1/2"	2"
Porting code	S	R	T	U	V	W	Y	X

*(NPT and SAE threads available on request)*

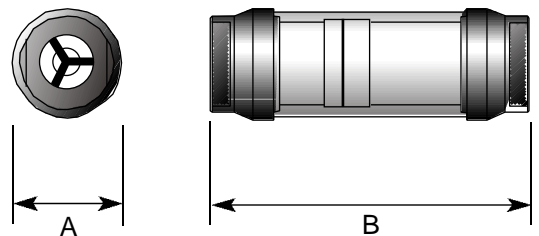

## Ordering code

WPB4A - 6HV - 10

Size code \_\_\_\_\_  
Porting code \_\_\_\_\_  
Model number (see Price list) \_\_\_\_\_

See illustrated price list for complete product selection guide with ordering codes

# WP Series Pneumatic Flow Monitor

- Flow rates from 1.5 to 1300 SCFM
- Select from aluminium, brass or stainless steel

The WP series in-line flow monitors are designed for continuous monitoring or intermittent use and ideal for checking air compressor output or testing pneumatic machinery and tools for correct air consumption. All monitors are calibrated at 21°C and 6.9 bar (100 psi) as standard, so eliminating the need for look-up tables for most applications. The tubular scale is easily read through the clear polycarbonate window and ensures checks can be made to determine compressor performance and setting of flow control valves.

The unit is fully sealed for weather tight or wash down applications. An optional pyrex safety glass window is available. Wetted seals are available in Buna (standard), Viton®, EPR or Kalrez®, so compatibility with all pneumatic systems in mobile, industrial or other applications is not a problem. The WP series flow monitors do not require straight inlet or outlet plumbing and can be fitted in any orientation. The advanced design of the sharp edged orifice ensures good reliability over a wide viscosity range and minimises the effect of contamination. Accuracy is 2.5% over the centre third of the scale and 4% over the entire flow range.



### Features

- Low cost solution
- Ideal for measuring compressor output
- Wide variety of flow ranges, 1.5 - 1300 SCFM
- Choice of aluminium, brass & stainless steel
- Pressure rating to 40 bar (70 bar stainless steel)
- Port sizes from 1/4" to 2"
- Ports available in BSP
- Direct reading
- Calibrated in SCFM at 21°C and 6.9 bar
- Accurate within 2.5% over mid-scale, 4% FSD
- Advanced stainless steel sharp edge orifice
- Unrestricted mounting in any orientation

## Specification

### Measuring accuracy

± 2.5% of full-scale in the centre third of the measuring range  
± 4% of full-scale over the entire scale range

### Repeatability

± 1% of full scale

### Flow measuring range

1.5 - 1300 SCFM (Standard cubic feet per minute)

### Maximum operating pressure

Aluminium & brass monitors 40 bar, stainless steel 70 bar

### Maximum operating temperature

115° C

### Pressure differential

See graphs below

### Standard calibration fluids

Air @ 21°C, 1.0 sg and 6.9 bar (100 psi)

## Pressure differential graphs categorised by size code

Series 3 (1/4" - 1/2")

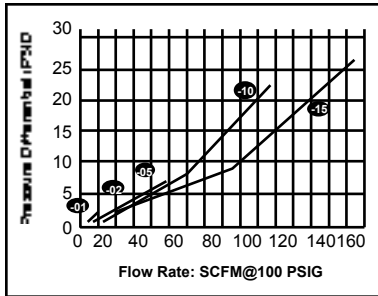

Series 4 (3/4" - 1")

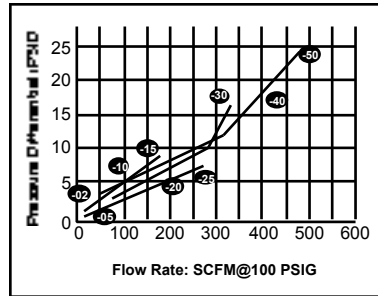

Series 5 & 5\* (1 1/4" - 2")

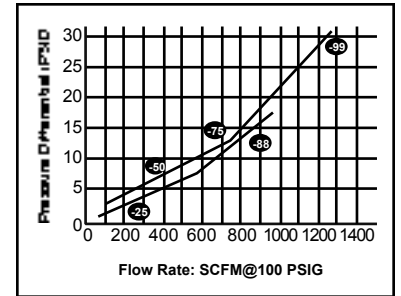

45 = Model number (see Sales Brochure)

## Construction

### Wetted components:

High-pressure casing, end ports and tapered shafts:	Aluminium, Brass & Stainless Steel
Seals:	Buna-N (STD), EPR, Viton® or Kalrez®
Transfer magnet:	Teflon® coated Alnico
Floating Orifice disc:	Stainless Steel
All other internal parts:	Stainless Steel

### Non-wetted components:

Window tube:	Polycarbonate (STD), Pyrex
Window seals:	Buna-N (STD), Teflon®

(Teflon® is a registered trademark of DuPont)  
(Viton® & Kalrez® are registered trademarks of Dow DuPont Elastomers)

## Dimensions

### Dimensions and porting options

Size code	2	3	4	5	5*			
Dim. A (mm)	32	48	60	90	90			
Dim. B (mm)	122	167	182	258	322			
Port sizes (inch BSP)	1/4"	3/8"	1/2"	3/4"	1"	1 1/4"	1 1/2"	2"
Porting code	S	R	T	U	V	W	Y	X

(NPT and SAE threads available on request)

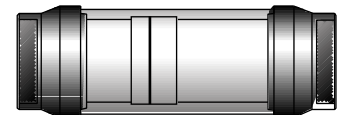
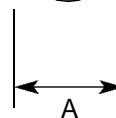

## Ordering code

WPG4B - 4AU - 05

Size code \_\_\_\_\_  
Porting code \_\_\_\_\_  
Model number (see price list) \_\_\_\_\_

See illustrated price list for complete product selection guide with ordering codes.

# WP Series Phosphate Ester Flow Monitor

- Flow rates from 0.5 to 550 lpm
- Select from aluminium, brass or stainless steel

The WP series in-line flow monitors are designed for continuous monitoring or intermittent use and ideal for checking power unit output or testing hydraulic machinery and tools for correct flow rates.

The tubular scale is easily read through the clear Pyrex window and ensures checks can be made to determine pump performance and setting of flow control valves. The unit is fully sealed for weather tight or wash down applications. Wetted seals are available in EPR (standard), Viton® or Kalrez®, so compatibility with all hydraulic systems in mobile, industrial or other applications is not a problem.

The WP series flow monitors do not require straight inlet or outlet piping and can be installed in any orientation. The advanced design of the sharp edged orifice ensures good reliability over a wide viscosity range and minimises the effect of contamination. Accuracy is 2.5% over the centre third of the scale and 4% over the entire flow range.



### Features

- Calibrated for use with phosphate esters
- Wide variety of flow ranges, 0.4 - 490 lpm
- Choice of aluminium, brass & stainless steel
- Pressure rating to 240 bar (420 bar stainless steel)
- Port sizes from 1/4" to 2"
- Ports available in BSP
- Direct reading
- Calibrated for phosphate ester
- Accurate within 2.5% over mid-scale, 4% FSD
- Advanced stainless steel sharp edge orifice
- Unrestricted mounting in any orientation

## Specification

### Measuring accuracy

± 2.5% of full-scale in the centre third of the measuring range  
± 4% of full-scale over the entire scale range

### Repeatability

± 1% of full scale

### Flow measuring range

0.4 - 490 lpm

(Phosphate ester flow rate monitors have a scale range equivalent to 0.93 x standard hydraulic oil range). See oil graphs below.

### Maximum operating pressure

Aluminium & brass monitors 240 bar, stainless steel 420 bar

### Maximum operating temperature

115° C

### Pressure differential

See graphs below

### Standard calibration fluids

DTE 25 @ 43°C, 0.873 sg. Density corrected to 1.16 sg.

## Pressure differential graphs categorised by size code

Series 3 (1/4" - 1/2")

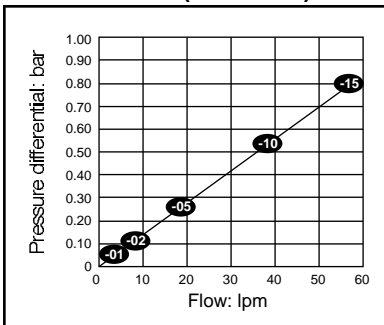

Series 4 (3/4" - 1")

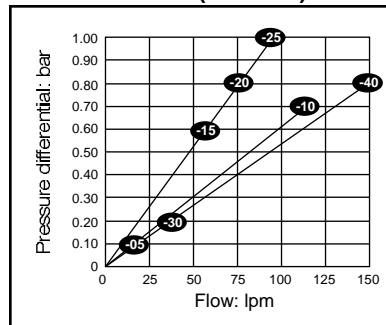

Series 5 & 5\* (1 1/4" - 2")

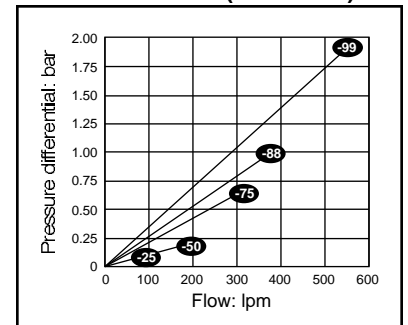

-15 = Model number (see Sales Brochure)

## Construction

### Wetted components:

High pressure casing, end ports and tapered shafts: *Aluminium, Brass & Stainless Steel*

Seals: *EPR w/Teflon® backup (STD), Viton® or Kalrez®*

Transfer magnet: *Teflon® coated Alnico*

Floating Orifice disc: *Stainless Steel*

All other internal parts: *Stainless Steel*

### Non-wetted components:

Window tube: *Pyrex*

Window seals: *Teflon®*

*(Teflon® is a Registered Trademark of DuPont)  
(Viton® & Kalrez® are Registered Trademarks of Dow DuPont Elastomers)*

## Dimensions

### Dimensions and porting options

Size code	2	3	4	5	5*			
Dim. A (mm)	32	48	60	90	90			
Dim. B (mm)	122	167	182	258	322			
Port sizes (inch BSP)	1/4"	3/8"	1/2"	3/4"	1"	1 1/4"	1 1/2"	2"
Porting code	S	R	T	U	V	W	Y	X

*(NPT and SAE threads available on request)*

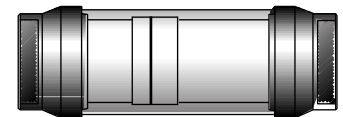
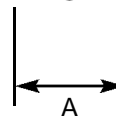

## Ordering code

WPP4A - 6HU -15

Size code

Porting code

Model number (see price list)

See illustrated price list for complete product selection guide with ordering codes

# WP Series High Temperature Flow Monitor

- Flow rates from 0.5 to 550 lpm
- Select from aluminium, brass or stainless steel

The WP series high temperature in-line flow monitors are designed for continuous monitoring or intermittent use on high temperature fluid systems up to 204°C (not suitable for steam).

The tubular scale is easily read through the clear Pyrex window and ensures checks can be made to determine pump performance and setting of flow control valves. Wetted seals are Viton®. The flow monitors are available in a choice of three different materials, aluminium, brass or stainless steel to suit your application.

The WP series flow monitors do not require straight inlet or outlet piping and can be installed in any orientation. The advanced design of the sharp edged orifice ensures good reliability over a wide viscosity range and minimises the effect of contamination. Accuracy is 2.5% over the centre third of the scale and 4% over the entire flow range.



## Features

- Suitable for temperatures up to 204°C
- Wide variety of flow ranges, 0.5 - 550 lpm
- Choice of aluminium, brass & stainless steel
- Pressure rating to 240 bar (420 bar stainless steel)
- Port sizes from 1/4" to 2"
- Ports available in BSP
- Direct reading
- Accurate within 2.5% over mid-scale, 4% FSD
- Advanced stainless steel sharp edge orifice
- Unrestricted mounting in any orientation

## Specification

### Measuring accuracy

± 2.5% of full-scale in the centre third of the measuring range  
± 4% of full-scale over the entire scale range

### Repeatability

± 1% of full scale

### Flow measuring range

0.5 - 550 lpm

### Maximum operating pressure

Aluminium & brass monitors 240 bar, stainless steel 420 bar (Note: See temperature / pressure de-rating chart)

### Maximum operating temperature

204°C (315°C model available)

### Pressure differential

See graphs below

### Standard calibration fluids

DTE 25 @ 43°C, 0.873 sg.

### Temperature De-rating for Aluminium & Brass Monitors

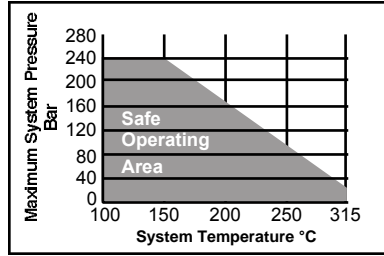

## Pressure differential graphs categorised by size code

Series 3 (1/4" - 1/2")

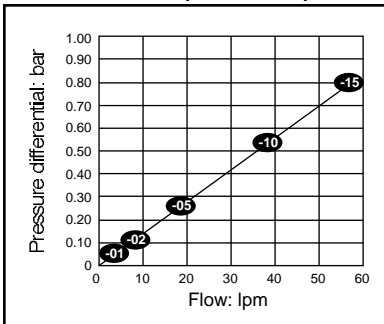

Series 4 (3/4" - 1")

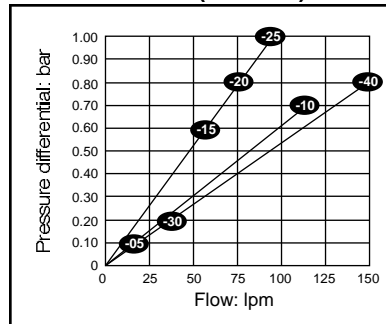

Series 5 & 5\* (1 1/4" - 2")

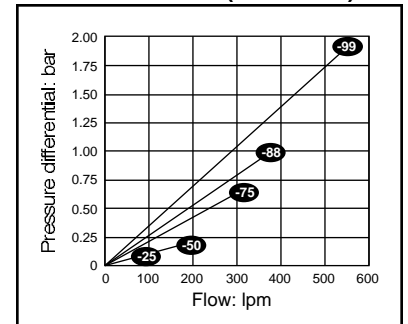

-15 = Model number (see Sales Brochure)

## Construction

### Wetted components:

High pressure casing, end ports and tapered shafts *Aluminium, Brass & Stainless Steel*

Seals: *Viton®*

Transfer magnet *Teflon® coated Alnico*

Floating Orifice disc: *Stainless Steel*

All other internal parts *Stainless Steel*

### Non-wetted components:

Window tube: *Pyrex*

Window seals: *Teflon®*

*(Teflon® is a registered trademark of DuPont)  
(Viton® & Kalrez® are registered trademarks of Dow DuPont Elastomers)*

## Dimensions

### Dimensions and porting options

Size code	2	3	4	5	5*			
Dim. A (mm)	32	48	60	90	90			
Dim. B (mm)	122	167	182	258	322			
Port sizes (inch BSP)	1/4"	3/8"	1/2"	3/4"	1"	1 1/4"	1 1/2"	2"
Porting code	S	R	T	U	V	W	Y	X

*(NPT and SAE threads available on request)*

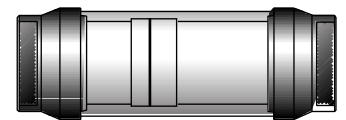
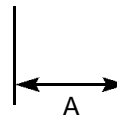

## Ordering code

WPH4A - 6HU -15

Size code \_\_\_\_\_  
Porting code \_\_\_\_\_  
Model number (see price list) \_\_\_\_\_

See illustrated price list for complete product selection guide with ordering codes

# WP Series Flow Monitor with Flow Rate Alarm

- Hydraulic or pneumatic models available
- Select from aluminium, brass or stainless steel

The WP series in-line flow rate alarms are ideal for protecting hydraulic or pneumatic systems by sounding an alarm if flow passes a preset level. Typical applications include monitoring the minimum flow in lubrication systems and protecting against high flows. A flow rate alarm will rapidly pay for itself by reducing down time and avoiding damage to critical equipment.

All WP flow rate alarms include all the features of a standard WP flow rate monitor in addition to having an easily adjustable dry contact switch. The switch connects via a standard Hirschmann plug and only a screwdriver is required for set-up. The unit is fully sealed for weather tight or wash down applications. The WP series flow monitors do not require straight inlet or outlet piping and can be installed in any orientation. The advanced design of the sharp edged orifice ensures good reliability over a wide viscosity range and minimises the effect of contamination. Accuracy is 2.5% over the centre third of the scale and 4% over the entire flow range.



### Features

- Economic early warning solution
- Easily adjustable, dry contact alarm settings
- Available for fluids or air
- Wide variety of flow ranges
- Choice of aluminium, brass & stainless steel
- Port sizes from 1/4" to 2"
- Ports available in BSP
- Direct reading
- Accurate within 2.5% over mid-scale, 4% FSD
- Advanced stainless steel sharp edge orifice
- Unrestricted mounting in any orientation
- Double break switches available on request

## Specification

### Measuring accuracy

±2.5% of full-scale in the centre third of the measuring range  
±4% of full-scale over the entire scale range

### Repeatability

± 1% of full scale

### Flow measuring range

Hydraulic: 0.5 - 550 lpm, Pneumatic: 1.5 - 1300 SCFM

### Maximum operating pressure

Hydraulic: Aluminium & brass monitors 240 bar, stainless steel 420 bar  
Pneumatic: Aluminium & brass monitors 40 bar, stainless steel 70 bar

### Maximum operating temperature

115° C

### Pressure differential

See graphs below

### Standard calibration fluids

Hydraulic: DTE 25 @ 43°C (40 cSt), 0.873 sg  
Pneumatic: Air @ 21°C, 1.0 sg and 6.9 bar (100 psi)

### Alarm switch dead-band

4% of full scale

### Alarm switch contacts

SPDT (dry contact), rating 10 amps and 1/4 hp, 125 or 250 V AC, 1/2 amp, 125 V DC, 1/4 amp, 250 V DC; 3 amps, 125 V AC (Lamp load).

## Pressure differential graphs categorised by size code

Series 3 (1/4" - 1/2")

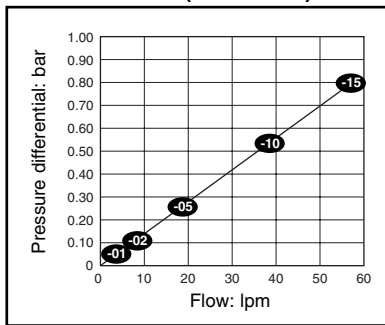

Series 4 (3/4" - 1")

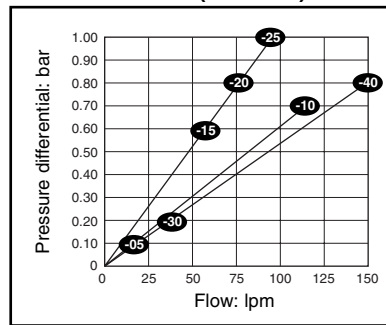

Series 5 & 5\* (1 1/4" - 2")

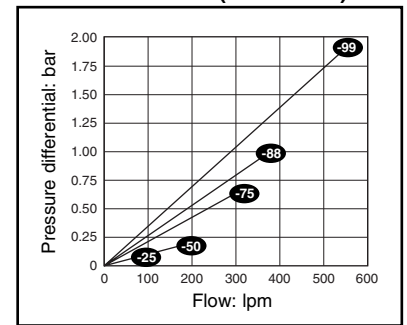

-15 = Model number (see Sales Brochure)

## Construction

### Wetted components:

High pressure casing, end ports and tapered shafts:	Aluminium, Brass & Stainless Steel
Seals:	Buna-N (STD), EPR, Viton® or Kalrez®
Transfer magnet:	Teflon® coated Alnico
Floating Orifice disc:	Stainless Steel
All other internal parts:	Stainless Steel

### Non-wetted components:

Window tube:	Polycarbonate (STD), Pyrex
Window seals:	Buna-N (STD), Teflon®

(Teflon® is a registered trademark of DuPont)  
(Viton® & Kalrez® are registered trademarks of Dow DuPont Elastomers)

## Dimensions

### Dimensions and porting options

Size code	3	4	5	5*	
Dim. A (mm)	167	182	258	322	
Dim. B (mm)	85	90	90	90	
Dim C (mm)	80	90			
Dim D (mm)	47	47			
Porting code	1/4"   3/8"   1/2"	3/4"   1"	W	Y	X

(NPT and SAE threads available on request)

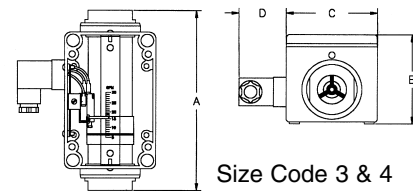

Size Code 3 & 4

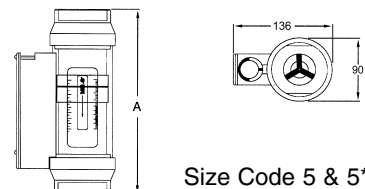

Size Code 5 & 5\*

## Ordering code

WPM4A - 6HU - 15

Size code \_\_\_\_\_  
Porting code \_\_\_\_\_  
Model number (see price list) \_\_\_\_\_

See illustrated price list for complete product selection guide with ordering codes.

# Low Cost In-Line Flow Indicator Test Kit

- 30 lpm
- 60 lpm
- 120 lpm
- 180 lpm
  
- Up to 420 bar

The 'In Line Flow Indicator Test Kit' comprises a direct acting flow indicator with built in thermometer, a loading valve and a pressure gauge all built into a strong steel case with a removable lid. This kit provides the ideal solution for servicing and commissioning hydraulic circuits on agricultural and other mobile equipment.

The unit is self contained and requires no electrical power. The dials are clear and easy to read. Installation is extremely simple and the test kit can be connected into either the pressure or return lines. The loading valve and pressure gauge allow a progressive build up of system pressure in complete safety.

The test kit provides the service engineer with quick, accurate and simple performance testing of pumps, valves and other aspects of hydraulic circuits.



## Features

- **LOW** cost, rugged construction
- **MEASURES** Flow, Pressure, Temperature
- **ACCURACY** within 4% FSD
- **LARGE** clear easy to read dials
- **SMOOTH** pressure control up to 420 bar 6000 psi
- **WIDE** range of operation, 2 to 180 lpm (1/2 to 40 gpm)
- **SAFE** to use, Internal oil by-pass protect system and operator against accidental over-pressure.

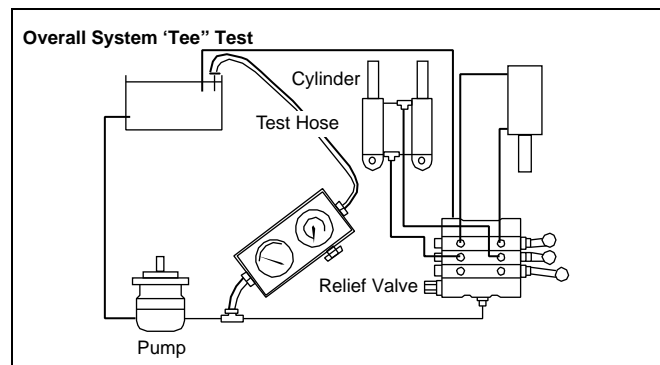
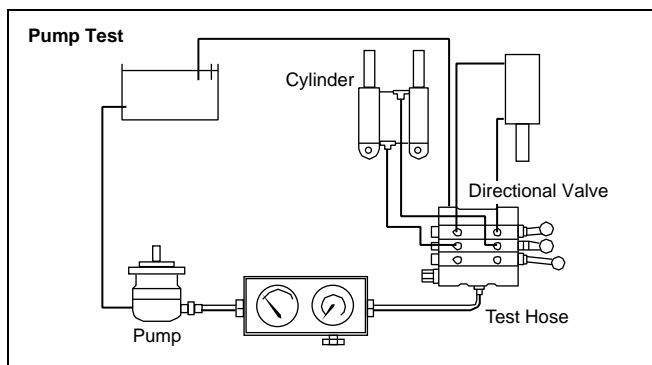

## Specifications

Model No.	Part No	Flow Range		Max.Working Pressure		Temperature Range	
		lpm	gpm	bar	psi	°C	°F
FIK 30 ABOT	FT5594 - 01	2 - 30	0.5 - 8	420	6000	10 - 80	50 - 180
FIK 60 ABOT	FT5594 - 02	3 - 60	0.8 - 14	420	6000	10 - 80	50 - 180
FIK120 ABOT	FT5594 - 03	5 - 120	1.2 - 26	420	6000	10 - 80	50 - 180
FIK180 ABOT	FT5594 - 09	8 - 180	2.0 - 40	420	6000	10 - 80	50 - 180

### Connections

By flexible hoses (1/2 - 1 metre recommended length)

Inlet Port: 3/4" BSPF

Outlet Port: 1/2" BSPF

### Adaptors

Fittings are supplied as standard to provide inlet and outlet connections.

Models FIK 30 ABOT 1/2" BSPF Male.

Models FIK 60 ABOT 1/2" BSPF Male.

Models FIK 120 ABOT 3/4" BSPF Male.

Models FIK 180 ABOT 3/4" BSPF Male.

Other adaptor fittings available. Consult Sales Office.

### Measurement and Indication

#### Flow

Measured by a tapered metering piston moving within a fixed, sharp edged orifice, designed to minimise the effect of changes in temperature and viscosity. The piston movement is proportional to the change in flow rate.

**Accuracy:** ± 4% of full scale.

#### Pressure Drop

FIK 30 ABOT 3 bar FIK 60 ABOT 5 bar

FIK 120ABOT 15 bar FIK 180 ABOT 25 bar

At full flow with oil viscosity of 28 centistokes

#### Pressure

Glycerine filled 63mm (2 1/2") pressure gauge 0 - 420 bar (0 - 6000 psi) gives a continuous reading of system pressure.

**Accuracy:** ± 1.6% of full scale.

#### Temperature

Indicated in °C and °F by a thermometer set in rubber compound and built into the flowblock to measure temperature changes in the fluid passage.

**Accuracy:** ± 2 °C

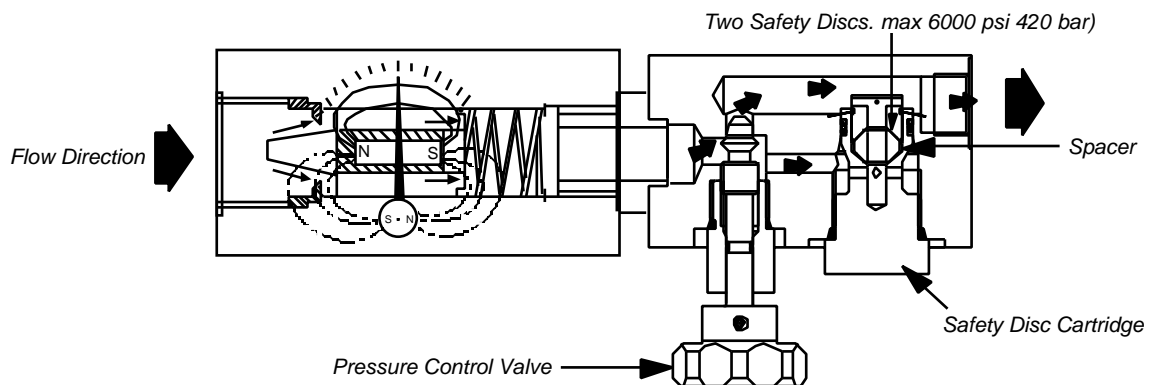

### Construction

#### Flow Block

Solid High tensile flow block houses a metering piston which moves against a calibrated spring. The piston is magnetically coupled to a rotary pointer to provide a direct reading of flow on a clear 63mm (2 1/2") diameter flow scale calibrated in lpm and gpm. Both flow and temperature scales are shielded behind impact resistant windows. The whole unit is fully sealed and very strong.

#### Case

The complete unit is built into a strong steel case which provides full protection against accidental damage during testing. A detachable lid and end plate allow easy removal to replace safety discs.

#### Dimensions / Weight

350 x 125 x 115mm (13.75 x 5 x 4.5 inches)

4.5 kg (10 lbs)

#### Loading Valve and Pressure Gauge

The HV1 00 loading valve is connected directly to the flow block and a 420 bar, 6000 psi pressure gauge is mounted in the inlet section of the loading valve. The valve is easy to operate and, combined with the pressure gauge, allows sensitive and progressive control of system pressure throughout the working range.

#### Safety Discs

Protection against over pressure is provided by two internal safety discs which relieve at 440 bar, 6400 psi without external spillage. The safety discs are housed in a cartridge and are easily replaceable

### General

#### Other Applications.

Aluminium free units suitable for Mining, Offshore and High Pressure Water applications are available.

Consult Sales Office.

#### How to order

Specify Model from table above together with any adaptor fitting required. Webster Model FIK 120 ABOT is a 5 - 120 lpm, 1.2 - 26 gpm test kit suitable for up to 420 bar, 6000 psi operation.

# RFIK Series Low Cost Hydraulic Tester

- 120 lpm
- 180 lpm
  
- Up to 420 bar

The RFIK Reversible Flow Indicator Test Kit provides the ideal solution for servicing and commissioning hydraulic circuits on agricultural and other mobile machinery.

The kit comprises of a direct acting flow indicator with built in thermometer, a loading valve and a pressure gauge all built into a strong steel case with a removable lid.

The unit is self contained and requires no electrical power. The dials are clear and easy to read. Installation is extremely simple and the test kit can be connected into either the pressure or return lines. The loading valve and pressure gauge allow a progressive build up of system pressure in complete safety.

The test kit provides the service engineer with quick, accurate and simple performance testing of pumps, motors, valves, cylinders and complete hydraulic circuits.



*Model RFIK 180 ABOT*

## Features

- **MEASURES** Flow, Pressure, Temperature
- **ALLOWS** reversible flow
- **FLOW** accuracy  $\pm 4\%$  FSD
- **WIDE** flow range
- **LARGE** easy to read dials
- **NO** batteries required
- **SMOOTH** pressure control up to 420 bar (6000 psi)
- **SAFE** to use, with INTERPASS internal safety protection system. Protects system and operator against accidental over-pressure in both flow directions

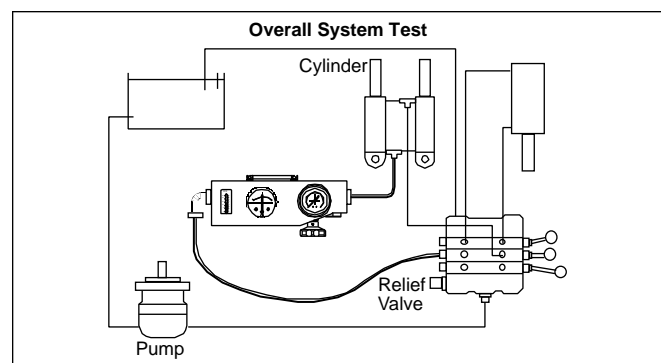
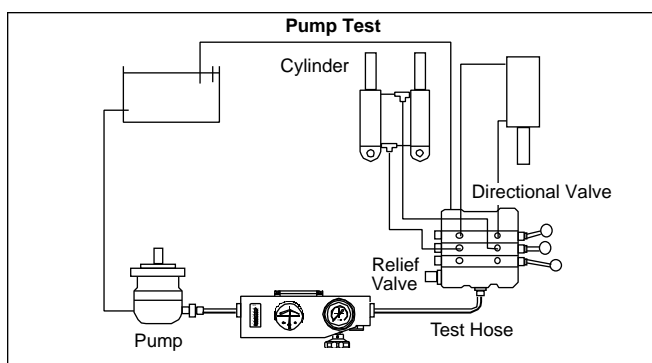

## Specification

Model No.	Part No.	Flow Range		Max. Working Pressure		Temperature Range	
		lpm	gpm (US)	bar	psi	°C	°F
RFIK 120 ABOT	FT8686 - 03	5 - 120	1.3 - 32	420	6000	10 - 80	50 - 180
RFIK 180 ABOT	FT8686 - 09	8 - 180	2.1 - 48	420	6000	10 - 80	50 - 180

## Connections

By flexible hose (1/2 - 1 metre recommended length)  
Models RFIK 120 & 180 ABOT

Inlet Port 1" BSPF  
Outlet Port 1/2" BSPF

## Adaptors

Adaptors are fitted as standard to provide inlet & outlet connections

Model RFIK 120 ABOT 3/4" BSPF Male  
Model RFIK 180 ABOT 3/4" BSPF Male

## Measurement and Indication

### Flow

Measured by a tapered metering piston moving within a fixed, sharp edged orifice designed to minimise the effects of changes in temperature and viscosity. The piston movement is proportional to the change in flow rate. In reverse the piston moves back to allow the flow to return at low pressure.

**Accuracy:** ± 4% of full flow.

### Pressure Drop (In both flow directions)

RFIK 120 ABOT 15 bar

RFIK 180 ABOT 35 bar

At full flow with oil viscosity 28 centistokes.

### Pressure

Glycerine filled 63mm (2 1/2") pressure gauge 0 - 420 bar (0 - 6000psi) gives a continuous reading of system pressure.

**Accuracy:** ± 1.6% of full scale

### Temperature

Indicated in °C and °F by a thermometer set in rubber compound and built into the flowblock to measure temperature changes in the fluid passage.

**Accuracy:** ± 2 °C

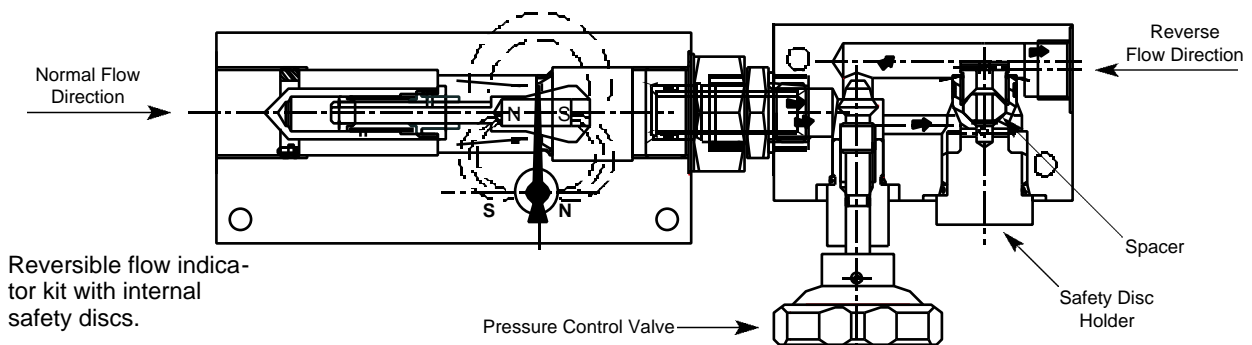

## Construction

### Flow Block

Solid high tensile flow block houses a metering piston and guide, the piston moves against a calibrated spring housed in a guide. The piston can move in both directions allowing flow from either the inlet and outlet port as required. The piston is magnetically coupled to a rotary pointer to provide a direct reading of flow from the inlet direction on a clear 63mm (2 1/2") diameter flow scale calibrated in lpm and gpm. Both the flow and the temperature scales are shielded behind impact resistant windows and protected by a metal cover. The whole unit is fully sealed within a strong metal cover.

### Case

The complete unit is built into a strong steel case which provides full protection against accidental damage during testing. A detachable lid provides access to the instrument dials and the safety disc cartridge is easily accessed to replace safety discs.

### Dimensions/Weight

310 x 105 x 120 mm (12.25 x 4.125 x 4.875 inches)

5 kg (11 lbs)

### Loading Valve and Pressure Gauge

The HV100 loading valve is connected directly to the flow block and a 420 bar, 6000 psi pressure gauge is mounted in the inlet section of the loading valve. The valve is easy to operate and, combined with the pressure gauge, allows sensitive and progressive control of system pressure throughout the working range.

### Safety Discs

Protection against over pressure is provided by two internal safety discs which relieve at 440 bar, 6400 psi without external spillage. The safety discs are housed in a cartridge and are easily replaceable.

### Other Products.

Aluminium free flow indicator test kits suitable for Mining / Offshore and High Pressure Water applications are available. Consult sales office.

### How to order

Specify Model from table above together with any adaptor fitting required. Webster Model RFIK 120 ABOT is a 5 - 120 lpm, 1.2 - 26 gpm test kit suitable for up to 420 bar, 6000 psi operation.

