



C2000 Hydraulic data acquisition system



User Guide

www.webtecproducts.com

Contents

1. Introduction	4
1.1 Webtec C2000.....	4
2. References	6
3. Getting Started	7
3.1 Module Hardware Setup.....	7
3.1.1 Midbox Iss' A and B (No Module LED).....	7
3.1.2 Midbox Iss' C - up (LED on each Module Input Panel).....	8
3.1.3 High Current/Voltage Option - Hardware Information.....	9
3.3 Quick tutorial.....	12
4. Channel Configuration	22
4.1 Hard Channels.....	22
4.2 Virtual Channels.....	25
4.3 Custom Units.....	26
5. Layouts	29
5.1 Layout Management	29
5.2 Editing the Layout Panels	30
6. Data Logging	35
6.1 Performing a Log Process	35
6.2 Reviewing Acquired Data.....	37
7. Report Generation	39
7.1 Certificate of Test Report	39
7.2 Snapshot Report.....	41
7.3 Analysis Report.....	42
7.4 Printing and Saving a Report.....	42

7.5 Using Different Images in Reports	43
8. Analysis Tools.....	45
8.1 Importing Data into Analysis	45
8.2 Customising the Analysis Graph.....	46
8.3 Analysis Report.....	46
9. Importing and Exporting Files	47
9.1 Exporting a data file.....	47
9.2 Exporting an Analysis file	47
9.3 Importing data files into the C2000	47
9.4 Importing data files into a spreadsheet package	47
10. Troubleshooting.....	49
10.1 Hardware connection	49
10.2 Report preview	49
10.3 Navigating the menus with the keyboard	49

1. Introduction

1.1 Webtec C2000

The Webtec C2000 system is designed to provide a versatile and customisable hardware and software package for the measurement, logging and analysis of test data from the Webtec range of fluid measurement sensors.

The hardware consists of the C2000 Midbox, housing a customisable data acquisition and conditioning system, accepting up to 64 analogue channels, 48 digital channels, or a selective range of the two. The C2000 Midbox can sample each line at up to 2kHz^{*}, even when all channels are connected. Expansion of C2000 Midbox systems with only a few channels is easily achieved with the simple addition of extra modules. The on-board software automatically detects the hardware configuration on boot-up, making it available without the need for any user reconfiguration.

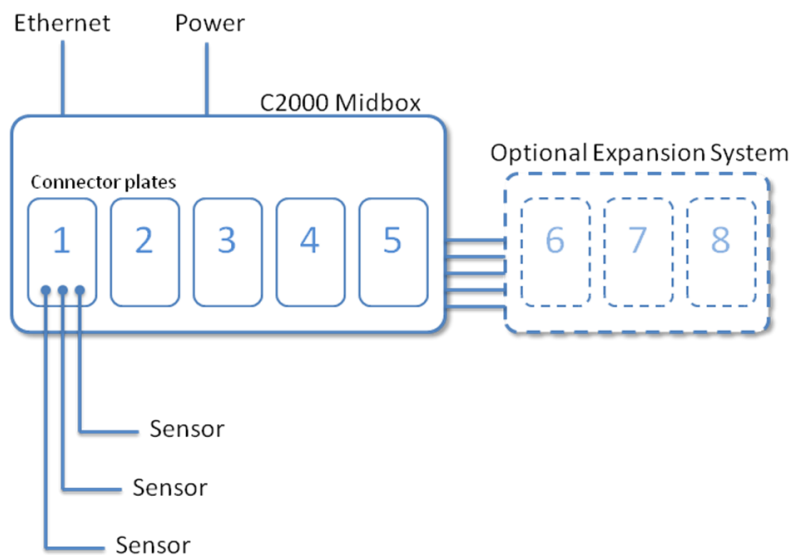

Figure 1.1 Simplified schematic of the C2000 Midbox

The C2000 software installs on a standard networked PC. The application complements the Midbox system by automatically synchronising its own configuration to suit the connected hardware. Three configurable display panels are available for generating customised layouts, plus a fourth panel for graphical representations. These are complemented by report generation and analysis tools.

This guide describes the operation of the C2000 software application, with basic coverage of the hardware system. For more technical guidance, and all other queries, please refer to the companion document [ref 1].

The following conventions are used in this guide:

» The » symbol denotes navigation through a series of linked menu items.

* Nominal maximum sampling rate

monospace Text in this format denotes a filename, numeric or string entry field

Bold Text in this format denotes a menu selection or item

italic Text in this format denotes a noteworthy point

2. References

Intentionally left blank.

3. Getting Started

The C2000 software always starts up with the last used layout configuration. When no layout exists, such as on the very first launch following installation, the C2000 software will instead show an empty layout screen. In this case, it is necessary to define and save a layout and channel configuration before data acquisition can be performed.

A layout contains all the definitions and settings associated with your use of the C2000 software, such as channels and panel designs. Test data files are also stored alongside the layout definition on your computer. Refer to section **5 Layouts** for more information on Layouts.

3.1 Module Hardware Setup (Flow, Press & Temp)

3.1.1 Midbox Iss' A and B (No Module LEDs)

C2000 M12input connector pin assignments are configured to work with sensors and cables supplied by Webtec – see table 3.1.1. To enable pressure transducers, flow blocks and temperature sensors to work with the C2000 system additional switch settings need consideration.

Pressure transducers supplied by Webtec require specific switch settings to be made on each channel they are connected too. Undesirable effects on pressure signal integrity may occur if the input connector PCB switches are not selected appropriately.

If the Sensors have been supplied with the C2000 system then the channels have been configured appropriately for the sensors ordered, provided they are connected according to the supplied Channel Configuration Sheet. If you wish to move the pressure sensors to another channel or add new pressure sensors then the switches on the back of the Module input connector PCB must be configured.

To gain access to the switches the top panel of the C2000 box must be removed. There are eight banks of double switches on the rear of the PCB (figure 3.1.1), each mounted approximately behind its corresponding connector. Configure the switches:

- **To use the input for a pressure sensor** the LEFT HAND switch should be ON and the RIGHT HAND switch OFF.
- **To use the input for a flow or temperature sensor** the RIGHT HAND switch should be ON and the LEFT HAND switch can be ON or OFF.

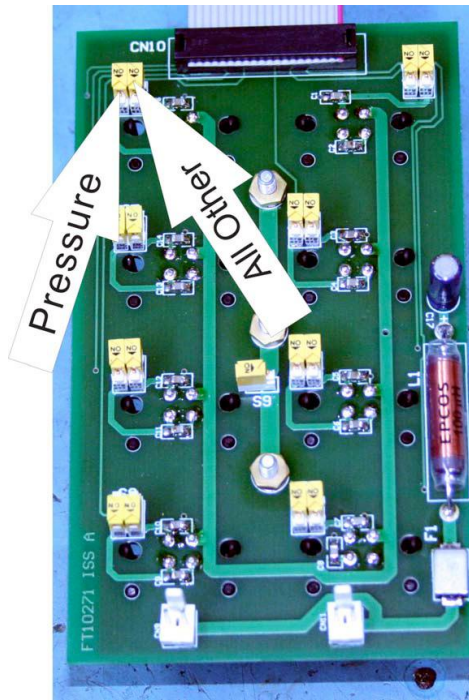

Figure 3.1.1 Rear of Module input connector PCB.

Channel	Connections	Function	Hardware Config channel
4-20mA	Pin1 = +24Vs Pin2 = signal. Pin3 = signal. Pin4 = n/c.	Flow, pressure, temperature, Aux-mA.	Mod x:x NB. observe switch settings.
TTL	Pin1 = +24Vs Pin2 = TTL signal Pin3 = Gnd. Pin4 = n/c.	Speed, Aux-TTL	Mod x:x

Table 3.1.1. Module input pin connections pre-2012.

3.1.2 Midbox Iss' C and above (LED on each Module Input Panel)

Input connection detail has been changed to bring the C2000 in line with the Webtec product range of sensors, see table 3.1.2. The change improves the system setup because there are no hardware switches to configure.

All sensors supplied from 2012 onwards have their pin configurations aligned with the C2000 inputs such that the supplied cables will work connected to any channel (NOTE: 4-20mA & TTL modules are not compatible). However, flow sensors supplied pre 2012

may require an adaptor cable for compatible operation – contact Webtec sales for guidance.

One further enhancement to the input connector panels is the addition of a power status LED located between the top two inputs, ie. 1 and 2. This confirms sensor power is available at the connectors when the LED is illuminated.

Channel	Connections	Function	Hardware Config channel
4-20mA	Pin1 = +24Vs Pin2 = n/c. Pin3 = signal. Pin4 = n/c. Pin5 = Gnd.	Flow, pressure, temperature, Aux-mA.	Mod x:x
TTL	Pin1 = +24Vs Pin2 = TTL signal Pin3 = Gnd. Pin4 = n/c. Pin5 = n/c.	Speed, Aux-TTL	Mod x:x

3.1.2. Module input pin connections, 2012 onwards.

3.1.3 High Current/Voltage Option - Hardware Information

To enable the C2000 data logging system to record high currents such as solenoid drives and voltages from third party sensors this interface PCB conditions the signals to an acceptable range. Table 3.1.3 details the pin connections for the high current module input panel.

The internal PCB has two independent current and voltage measuring channels, four channels in total. The channels are configured to customer requirements and can be scaled as follows:

1. Current channel 1 can be scaled from ± 1 to ± 3 Amps with the output signal set at 12mA for zero current.
2. Current channel 2 can be scaled from ± 1 to ± 3 Amps with the output signal set at 12mA for zero current.
3. Voltage channel 1 can be scaled at 0-5 or 0-10volts with the output signal scaled at 4mA for zero volts and 20mA for 5 or 10volts.
4. Voltage channel 2 can be scaled at 0-5 or 0-10volts with the output signal scaled at 4mA for zero volts and 20mA for 5 or 10volts.

The two current channels are protected by appropriate fuses and have independent selectable low pass filters with a cut off frequency set at 5Hz (see figure 3.1.3.1 for location). With the links in the bottom position there is no filtering which could result in unstable measurements where PWM signals are involved!

Figure 3.1.3.1 shows a photo of the interface PCB and is annotated with arrows indicating important user information. DO NOT adjust any of the potentiometers.



Figure 3.1.3.2. High current & voltage input connector module.

Channel	Connections	Function	Hardware Config channel
1	RED = +ve current BLK = -ve current	High Current input	Mod x:1
2	RED = +ve current BLK = -ve current	High Current input	Mod x:2
3	Pin1 = +24Vs Pin2 = V signal i/p Pin3 = Gnd. Pin4 = Gnd.	Voltage input	Mod x:3
4	Pin1 = +24Vs Pin2 = V signal i/p Pin3 = Gnd. Pin4 = Gnd.	Voltage input	Mod x:4
DATA	Pin1 = 4-20mA i/p7 Pin2 = Gnd. Pin3 = 4-20mA i/p5 Pin4 = 4-20mA i/p6 Pin5 = RS232Rx Pin6 = RS232Tx Pin7 = 4-20mA i/p8 Pin8 = n/c	Icount Data, M12 connection option.	Mod x:7 (ISO ch C) Mod x:5 (ISO ch A) Mod x:6 (ISO ch B or NAS) Mod x:8 (moisture)
PWR	Pin1 = Relay N/C Pin2 = +15v output. Pin3 = Relay common Pin4 = Relay N/O Pin5 = n/c Pin6 = n/c Pin7 = Gnd. Pin8 = +24v output.	Icount Power, M12 connection option.	n/a

Table 3.1.3. High current & voltage connector arrangement - Ref Figure 3.1.3.2.

3.2 Quick tutorial

The following tutorial will guide you through the process of creating a new layout, configuring two channels of your hardware, creating a panel design, performing a log process and generating a report.

3.2.1 Creating a new layout

To create a new layout:

1. Select **File » Layout Manager** from the drop down menu.
2. The **Layout Manager** will appear. Select **New**, and enter **Tutorial** as the layout title, and select **OK**.

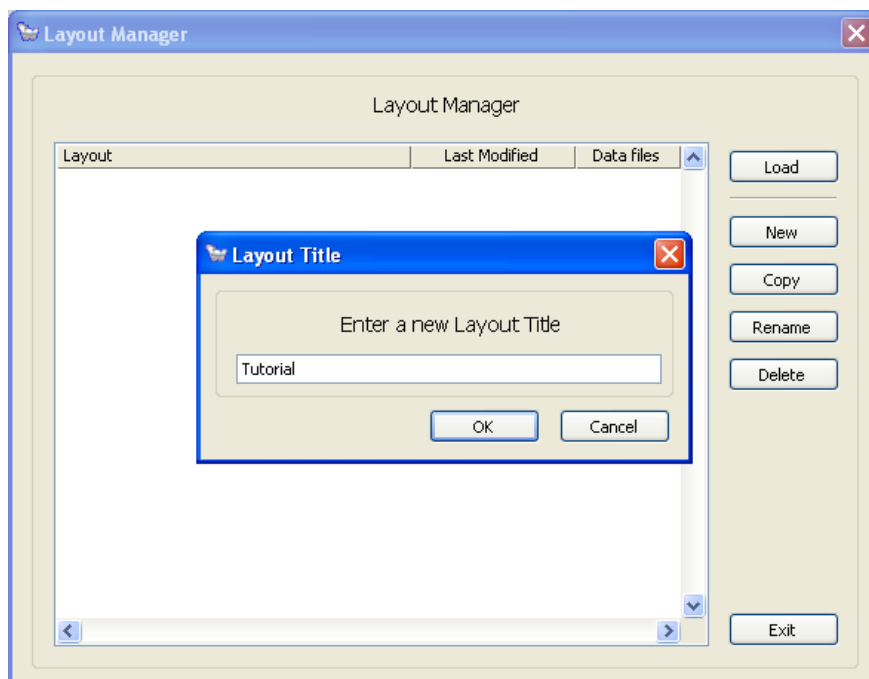

Figure 3.2 Creating a new Layout within Layout Manager

3. The new layout will be created and automatically selected.

3.2.2 Channel configuration

The following describes how to setup two example channels from the C2000 Midbox. Definitions for a current-based flow rate sensor and a pulse-type rotational speed sensor are described. Current measurement and frequency measurement modules are necessary on the C2000 Midbox to permit the configuration of these two sensors respectively.

Note: The exact build of your C2000 Midbox will define the list of available modules and channels in the C2000 software, and thus may not match the items described below.

Current type sensor:

1. Select **Data » Configure Channels** from the menu (shortcut **CTRL+C**) to open the channel configuration window.
2. Select **New** in the **Hard Channels** section to begin defining a new hard channel. The **Hard Channel Properties** window will appear.
3. Type **Flow Rate** into the **Channel Name** field.
4. Select **current (4-20mA)** from the **Signal Type** list, and choose Module 1, Line 1 (**Mod 1:1**) from the **Hardware Line** drop down list. *Note that the list of entries in the **Hardware Line** menu is determined from the C2000 Midbox setup.*
5. Select **flow** from the **Sensor type** list, and **litres/min** from the **Engineering units** list.
6. Select the **Calibration** button to open the **Channel Calibration** window.
7. We wish to use the simple calibration tools, so ensure the **Advanced»** button is **not** depressed. *Note: The default state for the **Advanced»** button is not depressed.*
8. Enter **0** into the **value for 4mA** field, and **400** into the **value for 20mA** field.
9. Change the **Precision in decimal places** to **0**, and select **OK**.

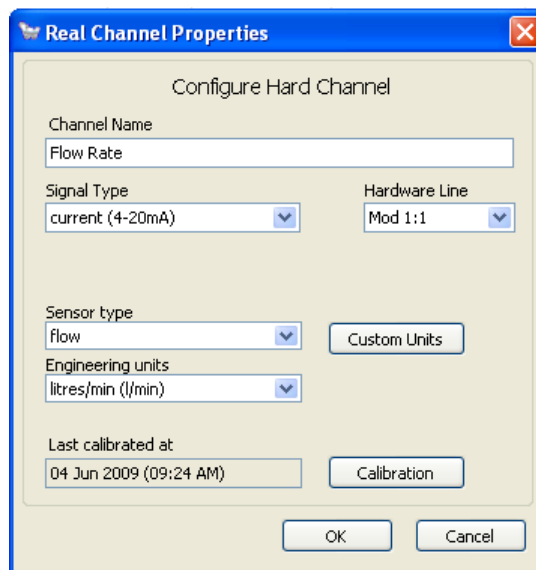

Figure 3.3 Defining a new current signal channel

Pulse type sensor:

1. Follow steps 1-2 above.
2. Type **Rotor Speed** into the **Channel Name** field.
3. Select **frequency (Hz)** from the **Signal Type** list, and choose Module 7, Line 1 (**Mod 7:1**) from the **Hardware Line** drop down list. *Note that the list of entries in the **Hardware Line** menu is specific to your C2000 Midbox setup.*

4. Select **speed** from the **Sensor type** list, and **RPM** from the **Engineering units** list.
5. Select the **Calibration** button to open the **Channel Calibration** window.
6. We wish to use the simple calibration tools, so ensure the **Advanced»** button is **not** depressed. *Note: The default state for the **Advanced»** button is not depressed.*
7. Enter **60** into the **Pulses per revolution** field.
8. Change the **Precision in decimal places** to **0**, and select **OK**.

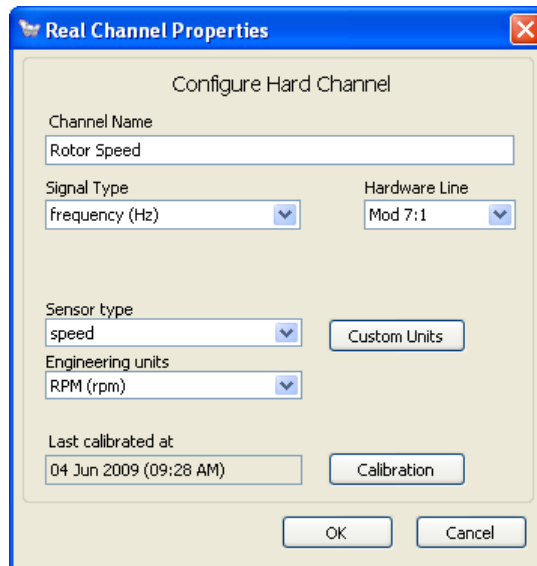

Figure 3.4 Configuring a new pulse input (frequency) channel

9. Select **OK** on the **Channel Configuration** window to accept all changes.

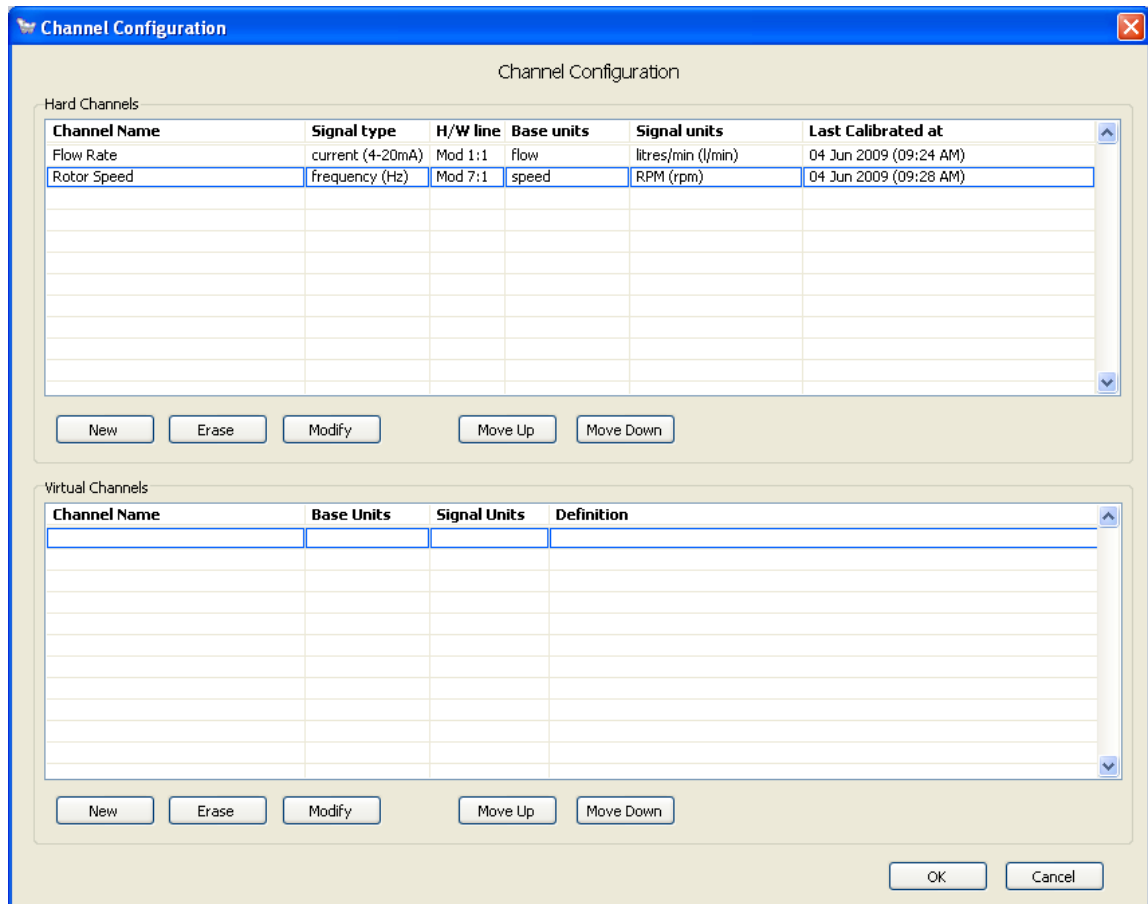

Figure 3.5 The Channel Configuration window

Depending upon the availability of modules on your C2000 Midbox, you will now see the two defined channels in the **Hard Channels** table list. If you do not have a frequency module in your C2000 Midbox for the second channel, instead create a second current sensor channel called **Pressure**, with units in **bar**.

3.2.3 Layout design

Navigate to the **Super Panel** through the drop down menu item **View » Show Panel » Super Panel** (shortcut key **F1**). The panel will be blank if there is no current layout definition.

To enter **configuration mode**, select **View » Configure » Configure Panels...** from the drop down menu (shortcut key **Ctrl+E**). You will be prompted to enter the password (the password is **webtec**). We can now use the right mouse button shortcut menus to create two digital indicators and two sliding scales to represent our data.

Use the right mouse button in the centre of the panel to open the configuration mode menu, and select **New Digital**. A new digital indicator will be created titled **New Digital**. Click and drag the indicator with the left mouse button to move it to a new location near to the top left corner of the panel area. Right mouse click the digital control to reveal the shortcut menu options for this digital control, and select **Associate » Flow Rate**. The title of the indicator will change to the name of the channel, with the engineering units displayed in brackets: **Flow Rate (l/min)**.

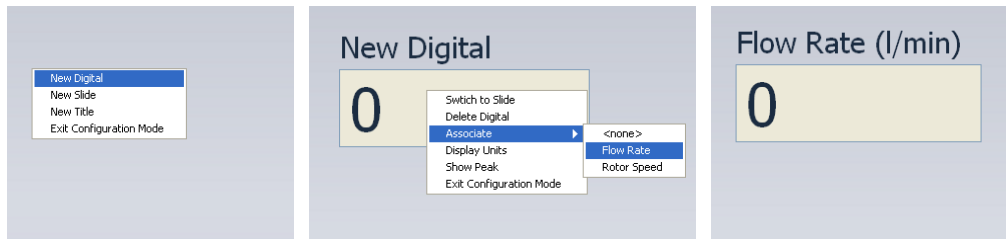

Figure 3.6 Creating a New Digital Indicator

Notice that if you have a suitable sensor connected to the Flow Rate channel, the values represented in the digital indicator are actual Live Data values. If you have no sensor connected, you will see zero.

To create a second digital indicator, use the right mouse button in the centre of the panel to open the configuration mode menu and select **New Digital**. Another new digital indicator will be created. Move this indicator to somewhere just below the first indicator. Associate this indicator with the **Rotor Speed** channel. The title of the indicator will change to the name of the channel with bracketed default units: **Rotor Speed (rpm)**.

We now wish to display a slide indicator beside each of the digital indicators. To do this, use the right click shortcut menu and select **New Slide**. Move the slide to a position somewhere close to the right hand side of the first digital indicator. Right click the slide, and select **Associate » Flow Rate**.

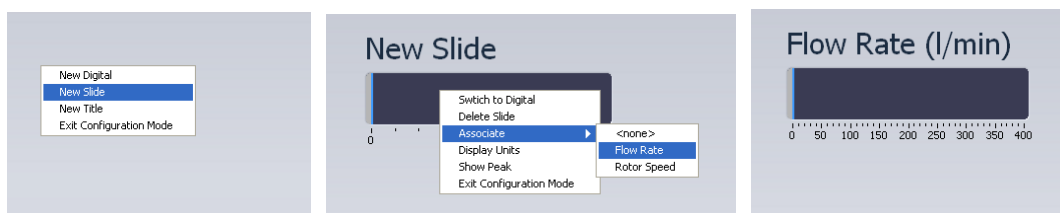

Figure 3.7 Creating a New Slide Indicator

Create a second slide indicator in the same manner as the first, place it beside the other digital indicator, and associate it with the second channel. If you wish, you can alter the default range of the scale by selecting the minimum or maximum value with the mouse pointer and entering a new value.

We can turn on Peak Recording for the slide indicators. Right click each slide indicator with the mouse and select **Show Peak** from the shortcut menu. The slide will now show a yellow tab that constantly marks the peak value of the data from the associated channel. Also, the title of the slide indicator now has a carat symbol at the beginning to indicate that peak value recording is turned on.

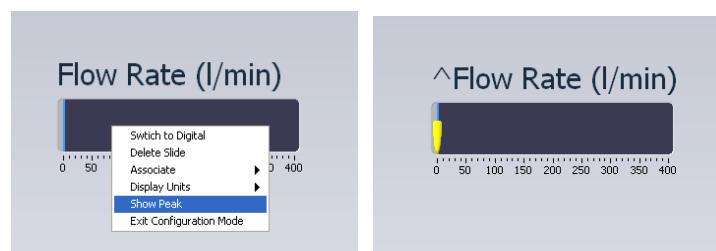

Figure 3.8 Enabling Peak Value Recording on a slide indicator

Do the same for the second slide indicator.

Finally, let's place a title above our four indicators. Right mouse click an area of free space on the panel and select **New Title** from the shortcut menu. A new title with the default words **New Title** appears under the mouse pointer. Click and drag this title to the top of the super panel, centralised over the four indicators. Either triple click the title to select the entire contents or use the delete key to erase the existing text, and then type **Example Super Panel**.

You should now have a **Super Panel** that looks similar to this:

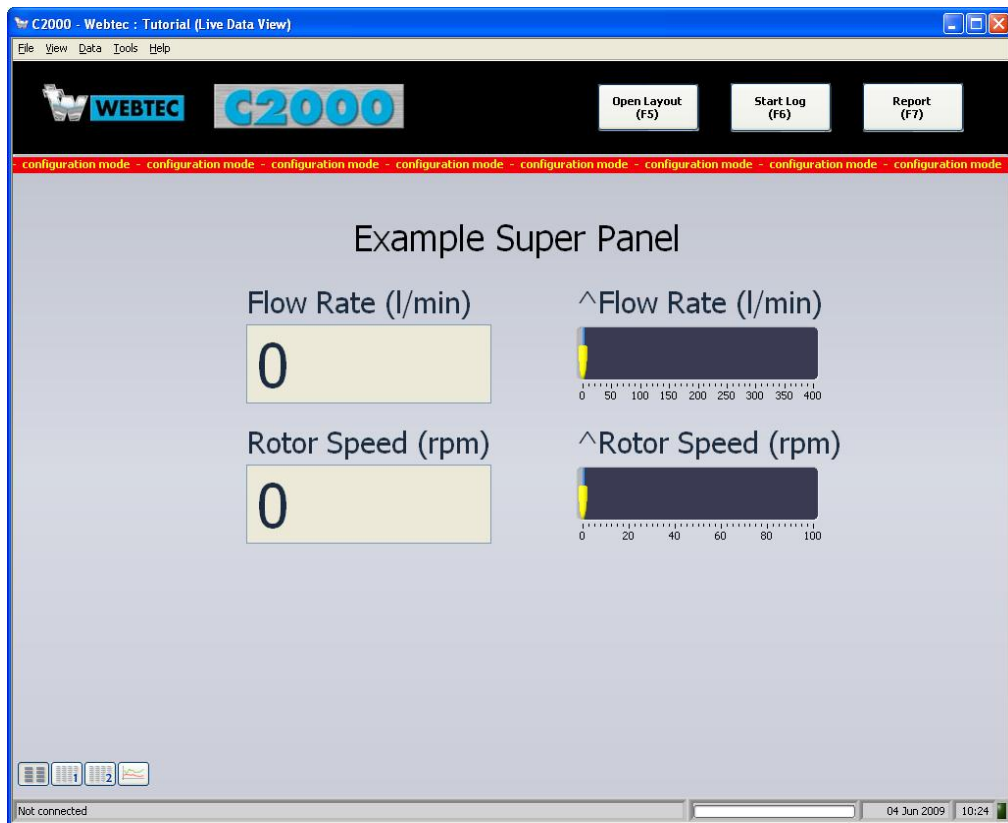

Figure 3.9 Super Panel layout example.

Finally, select **View » Configure » Configure Panels** (shortcut **ctrl+E**) from the drop down menu to exit configuration mode. When not in configuration mode, the indicators and titles can no longer be moved or edited.

Select **File » Save Layout** from the drop down menu (shortcut **ctrl+S**) to save the layout to the computer.

3.2.4 Performing a quick data acquisition

To perform a quick data log of the two channels as defined in the previous section, connect appropriate sensors to the C2000 Midbox inputs associated to the channel definitions. The C2000 Midbox will report default values without real sensors connected.

Switch to the graph panel by selecting **View » Show Panel » Graph Panel** (shortcut key **F4**) from the drop down menu. You will be presented with the graph panel of the C2000 software. Here, data is presented to you in a graphical plot form.

The graph is automatically configured to plot the data from those indicators created in the Super Panel. For this example, the two channels we associated with our front panel indicators are plotted on y-axes that match their engineering units respectively.

Select **Start Log** from the banner, or select **Data » Log Mode » Begin Logging** (shortcut key **F6**) to start an acquisition process. The **Begin Logging** window pops up. Choose **Continuous** from the **Logging Mode** list, enter **200** into the **Sample Rate (Hz)** field and **10** into the **Sample Time (secs)** field. Optionally, enter data into the text fields for **Title**, **Customer** etc. Press **Start Logging** to begin the log.

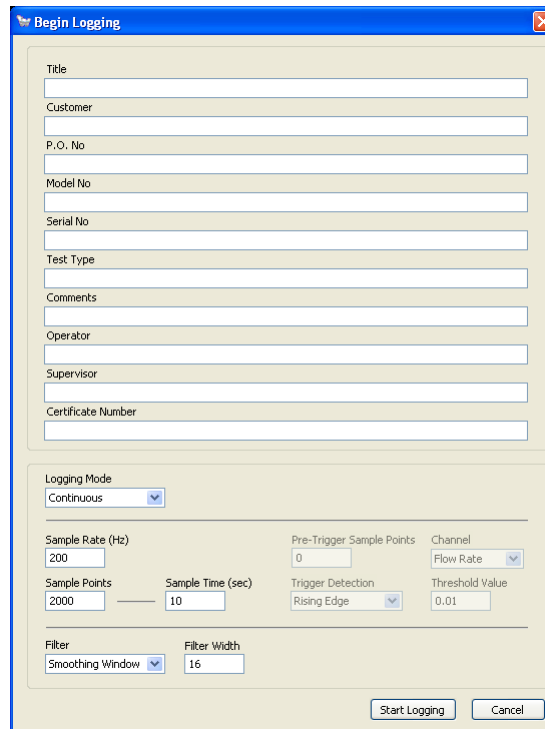

Figure 3.10 The Begin Logging window

The **Logging...** information strip will appear across the top of the panel indicating that a logging process is underway. Live data will be drawn in the graph plot during the acquisition process.

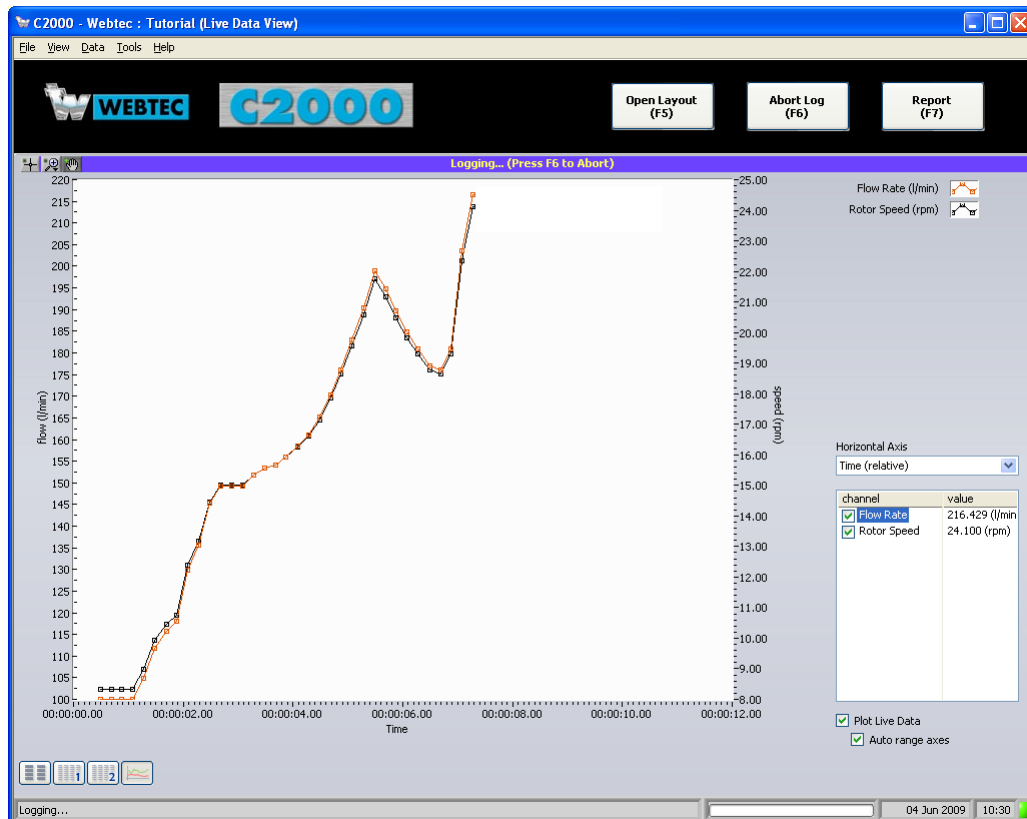

Figure 3.11 Example output from a Continuous data acquisition process

Note: Only default values will be returned from the C2000 Midbox without real sensors connected to the configured channels.

Once the acquisition is complete, the C2000 software will receive the logged data from the C2000 Midbox and pop up the **Logging Complete** window. Change the **Filename prefix** from **datafile** to **example**, optionally choose to alter any of the text fields, and then select **Save Data**.

The data will be presented in the graph panel plot. From here you can zoom and pan the data using the plot tools located at the top left of the panel area.

Note: The **Super Panel** will continue to show live data following a log process. To return to a live data mode in the **Graph Panel**, select the **Plot Live Data** checkbox located toward the bottom right.

3.2.5 Generating a Report

To generate a report of the data, including headers, tabulated data and a snapshot of the graph, select **Report** from the banner (shortcut key **F7**). The report panel will be shown.

A tabulated form of the logged data is presented, alongside options for customising the format of the report.

Change **Selected Data** to **Last of Range** in the **Certificate of Test Options** section, then select **Generate** under **Generate Report...**

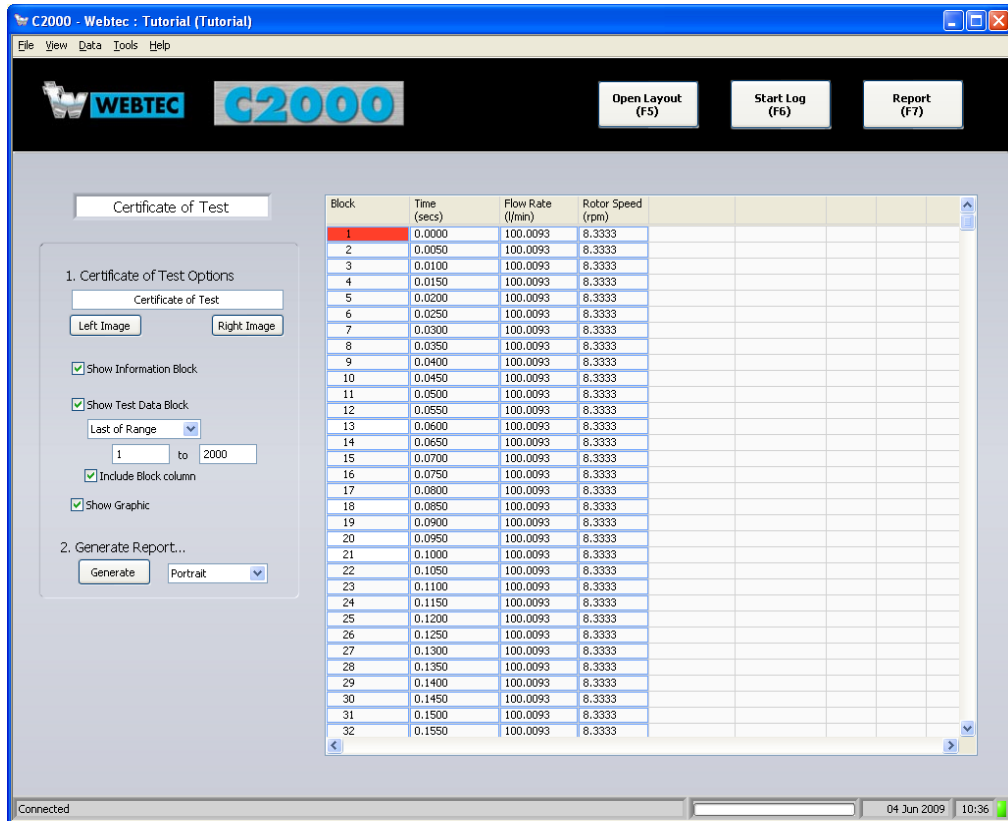

Figure 3.12 The Report Generation panel

A report viewer window will pop up, displaying the generated report as a PDF document. To print or save the document, use the **Print** and **Save As** shortcuts located towards the top left of the preview window. To close the window, select the cross icon in the title bar, or use **Alt-F4**.

4. Channel Configuration

The Channel Configuration window allows you to define channels for each connected sensor on the C2000 Midbox. Virtual channels can also be defined for the creation of simulated data based on real channel data.

To access the Channel Configuration window, select **Data » Configure Channels** from the drop down menu, or use the shortcut **Ctrl+C**.

When changes are made to the channel configuration, C2000 will attempt to propagate relevant changes back to any associated panel indicators and slides.

Note: Panel indicators maintain their own specific unit display type. Therefore, if a channel defined in units of Pascal was switched to Bar, any associated panel indicators would maintain their specific pressure units. If a Channel's base units were redefined from Pressure to, say, Flow Rate, all associated panel indicators would switch to a Flow Rate unit to maintain data conversion integrity.

The channel configuration definitions are embedded into the layout information and the C2000 data files created following each log process. When loading a data file, the channel configuration embedded within that file must match that of the current layout for the data to be correctly imported.

Note: Changing the channel configuration for a layout which has existing data files will result in those data files becoming incompatible with the open layout. Therefore, it is strongly recommended not to make alterations to the channel configuration of a layout file once data acquisition has been performed. Instead, create and work with a copy of the layout, making any channel configuration alterations to the copy.

4.1 Hard Channels

Hard channels are channels that relate directly to a module and line of the C2000 Midbox. There are up to eight C2000 Midbox modules available, with up to eight lines on each module.

Analogue current modules each have eight inputs. Connect sensors with a signal range of between 4-20 mA.

Frequency modules each have six inputs. Connect sensors that produce a standard TTL pulse signal.

4.1.1 Defining a Hard Channel

To define a new hard channel, either double-click an empty line in the hard channels table, or select **New**. The Configure Hard Channel window is shown with blank details in the fields. Populate the fields to define the new channel, and select OK.

4.1.1.1 Configure Hard Channel Window

The Configure Hard Channel window presents the user with all the properties of a hard channel. From here all settings can be modified.

- **Channel Name** The name identifier for the new channel
- **Signal Type** The signal type (current or frequency) for the new channel
- **Hardware Line** The physical module and channel input on the C2000 Midbox
- **Sensor Type** The units category of reported data from the sensor
- **Calibration Units** The specific engineering units for the data reported by the sensor for calibration

The **Custom Units** button opens the Custom Units window from where custom unit definitions can be created. See Section **4.3 Custom Units** for more details on Custom Units.

The Calibration button opens the Calibrate Hard Channel window.

4.1.1.2 Calibrate Hard Channel

The Calibrate Hard Channel window displays options specific to the signal type and sensor type of the channel under configuration. When the Advanced button is depressed, further options are presented to the user for improved calibration handling.

For all calibration types, the option to define the **Precision in decimal places** is available. This option allows for the sensor precision to be declared. For example, to have data rounded to the first decimal place, enter 1 into the **Precision in decimal places** field. Subsequently, all digital indicators on the Super Panel and Normal Panels will show values to one decimal place precisely.

Current type channels – Simple calibration

For a simple calibration of a current type sensor, enter the sensor's reading for 4 mA and likewise for 20 mA into the two fields. A linear calibration will be calculated from the two input values after you select **OK**.

Current type channels – Advanced calibration

In Advanced calibration mode, one may enter the offset and multiplier for the linear calibration directly, or create a live calibration for the sensor using the linear trend line tool.

To enter the offset and multiplier values for a linear calibration, enter values into **Offset Correction** and **Multiplier Correction** and select **OK**.

To create a linear calibration from values other than 4 mA and 20 mA, use the linear trend tool. Enter the sensor readings and the hardware values for the sensor (for example 100 l/min and 0.005 A for a flow rate sensor) and press **Record**. Do this for as many points as you wish (a minimum of two is required for the calibration to work, the more you enter the more accurate the resultant linear calibration). Then select **Calculate Linear Calibration** to perform a best fit to the recorded data points. The **Offset Correction** and **Multiplier Correction** fields will be completed automatically.

If you have a known sensor reading, such as that provided by a calibrated device, you can turn on **Get Measured Values**. Live raw data from the C2000 Midbox is then fed directly to the **Hardware value** field for the module and line of the channel.

For Advanced calibrations, the Deadband zone field is presented. This field reduces any incoming data from the sensor that falls within the deadband range to zero. This feature is useful for preventing slight noise or sensor drift from interfering with a true zero response.

Frequency type channels – Simple calibration

Frequency type channels are divided into two categories

- Flow sensors
- Speed sensors

Flow sensors are shipped with a calibrated K Factor value that the C2000 can directly use to calibrate your sensor. For the simple K Factor calibration panel, choose the sensor model from the **Part Reference** drop down list. The C2000 will automatically select the K Factor for your sensor.

For Speed sensors the number of pulses per revolution needs to be entered into the **Pulses per revolution** field.

Frequency type channels – Advanced calibration

For Flow sensors, choose the sensor model from the **Part Reference** drop down list. The default K Factor for that model will be entered into the **κ Factor** field. Replace this default K Factor with your sensors calibrated value.

For Speed sensors, enter the number of reported pulses per revolution into the Pulse per revolution field, and select Convert. This will convert the PPR value into the appropriate Offset and Multiplier values. You may correct these value manually if you wish.

For Advanced calibrations, the Deadband zone field is presented. This field reduces any incoming data from the sensor that falls within the deadband range to zero. This feature is useful for preventing slight noise or sensor drift from interfering with a true zero response.

4.1.2 Modifying an Existing Hard Channel

To modify a defined channel in the hard channels table highlight the channel and then select **Modify**. The channel details are presented in the Configure Hard Channels window.

4.1.3 Deleting an Existing Hard Channel

To delete a defined channel from the hard channels table, select the channel in the table and select **Erase**. The channel definition will be removed from the table.

4.1.4 Reorganising Hard Channels

The order in which defined hard channels appear in the table can be reorganised by selecting a hard channel in the table and selecting either **Move Up** or **Move Down**.

4.2 Virtual Channels

Virtual channels are channels that use a combination of real and/or other virtual channels with simple mathematical operators to create a new simulated channel. Virtual channels can be used to create new results based on a number of real channels that might follow a simple formula. For example, creating a virtual channel that is the subtraction of one pressure from another would provide a new channel representative of differential pressure. This could then be displayed and plotted just like any real channel.

4.2.1 Defining a Virtual Channel

To define a new virtual channel select **New** under the Virtual Channels list table in the Channel Configuration window. The Configure Virtual Channel window is shown with blank details in the fields. Populate the fields to define the new channel, and select **OK**.

4.2.1.1 Configure Virtual Channel Window

The Configure Virtual Channel window presents the user with all the properties of a virtual channel. From here all settings can be modified.

- Channel Name The name identifier for the new channel
- Sensor Type The units category of reported data from the sensor
- Engineering Units The specific units for the data reported by the sensor
- First Channel Choose the first channel upon which the virtual channel is dependent. This channel can be either real or virtual.
- Operator Choose a mathematical operator for the virtual channel calculation. These include add, subtract, multiply and divide with either a numerical constant or another channel.
- Second Channel If the Operator relates to another channel, select that second channel from the drop down list. This channel can be either real or virtual.
- Constant If the Operator relates to a constant, enter that constant value in this field.

- Temperature Temperature, default Celsius (degC)
- Velocity Translational velocity, default metres/second (m/s)

A number of standard units are selectable from menus within **Channel Configuration** and **Layout Editor**. When units are selected the C2000 converts the data as required.

The user is able to enter bespoke units through the **Custom Units Editor**. The **Custom Units Editor** is accessible from within the hard and virtual channel configuration panels. Once custom units are defined, they can be accessed from the **Sensor Type** menu as **Custom**. All defined custom units are then listed in the **Engineering units** list.

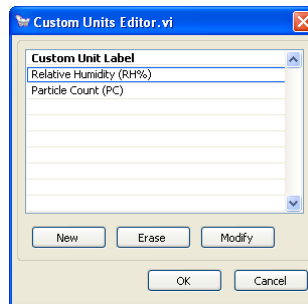

Figure 4.2 Custom Units Editor window

To create a new custom unit, select **New** from the Custom Units Editor. To modify an existing custom unit, select the custom unit from the table and select **Modify**. To delete a custom unit, select the unit from the table and select **Erase**.

Note: No changes are applied to the configured custom units until the OK button is pressed. Selecting Cancel will exit the Custom Units Editor window without applying any of the changes to the list of custom units.

Note: Custom units are saved to the layout definition, therefore new layouts will not contain any previously defined custom units. To create a new layout that contains any previously defined custom units, create a copy of the open layout instead.

4.3.1 Custom Unit Properties

When creating a new, or modifying an existing custom unit, the Custom Unit Properties window is used. This window shows the two required fields for defining a new custom unit.

- Custom Unit Title The full title of the custom unit, e.g. **Relative Humidity**.
- Custom Unit Units The short form for the units, e.g. **RH%**.

The formatted appearance for the custom unit is presented beneath the two fields, e.g. for the details above **Relative Humidity (RH%)**.

Note: Ensure no brackets are used in the Title definition.

Select **OK** to create the new custom unit.

Select **cancel** to abort the creation of a new custom unit.

5. Layouts

A layout is used to manage your use of the C2000 system. A layout must be created in order to save all your channel definitions, custom units and panel configurations. Each log process creates a data file that is tied to the open layout, allowing you to open saved data files and display the logged data effectively.

A saved layout stores the following information

- All Super Panel indicator, slide and title definitions
- All Normal Panel 1 and 2 indicator, slide and title definitions
- Currently defined Channels
- Currently defined Custom Units
- Certificate of Test report header images
- All Live Data smoothing settings

It is recommended that a new layout be created for every variation of channel configuration you need. This can easily be achieved by copying a layout, then altering your panel layouts and channel definitions.

5.1 Layout Management

5.1.1 Creating an empty layout

To create a new blank layout that contains no defined channels, nor panel indicators and slides, select **File » Layout Manager** from the drop down menu (shortcut **Ctrl+L**). The **Layout Manager** window will appear. Select **New**, and enter a name for the new layout. Any currently open layout will be closed and the new layout created and opened.

5.1.2 Creating a copy of a layout

To create a copy of any layout, use the **Layout Manager** window. The **Layout Manager** window can be accessed by selecting **File » Layout Manager** from the drop down menu (shortcut **Ctrl+L**).

Within the **Layout Manager** window, select the layout you wish to copy from the table, and select **Copy**. Enter a new layout title for the copy, and select **OK**.

To load the new copied layout, select the layout from the table and select **Load**. Any currently open layout will be closed and the new layout opened.

The copied layout will contain the defined channels, custom units, panel designs and report images from the original layout. The data files and analysis files will not be copied.

5.1.3 Deleting a layout

Layout definitions can be deleted from the **Layout Manager** window. The **Layout Manager** window can be accessed by selecting **File » Layout Manager** from the drop down menu (shortcut **Ctrl+L**).

To delete a layout, select the layout from the table in the Layout Manager window and then select **Delete**. The layout and any associated data files will be deleted from the PC. Note that the currently opened layout cannot be deleted.

Note: Once a layout has been deleted, neither it nor the data files associated with it can be recovered from within the C2000 software.

5.2 Editing the Layout Panels

There are four configurable panels for presenting data to the user. The first three allow for the creation of digital indicators and slides for presenting the acquired data. The fourth panel presents the data in a customisable graphical plot.

These panels are defined as follows:

- **Super Panel** The primary panel, upon which 12 large digital indicators, slides and titles can be created.
- **Normal Panel 1** Similar to the Super Panel. 48 small indicators and slides can be created. 12 titles can be created
- **Normal Panel 2** A second panel with the same features as Normal Panel 1.
- **Graph Panel** A graphical plot of channel data.

To edit the layout of indicator and slides in the Super Panel and Normal Panels 1 and 2, the user must enter Configuration Mode. Select **View » Configure » Configure Panels** from the drop down menu (shortcut **Ctrl+E**). The correct password must be entered in the password dialogue box (the password is **webtec**).

5.2.1 Super Panel

The Super Panel, as with the two Normal Panels, allows you to create and configure a number of digital indicators and slide indicators for displaying data from the C2000 Midbox. Digital indicators display the data in a numerical form whereas slide indicators use a horizontal bar to graphically represent the data.

5.2.1.1 Creating indicators

To create a new digital indicator or slide, click the right mouse button within a region of free space on the panel to reveal the configuration mode menu. Select either **New Digital** or **New Slide** to create a new digital or slide indicator. The new indicator will have the default title **New Digital** or **New Slide**.

To move an indicator from its current location, simply click and hold on the indicator with the left mouse button and move the indicator to the desired location. Release the mouse button to drop the indicator.

By default the C2000 snaps indicators to a grid to assist in aligning indicators on the panel. The **snap to grid** option can be disabled from the menu. Select **View » Configure » Snap to grid** to uncheck this option and disable grid snapping. To re-enable, simply select the same menu item once more.

Note: There is a total indicator and slide count limit of 12 for the Super Panel.

5.2.1.2 Channel Association

To display data in an indicator it must be associated with one of your configured channels. By default, newly created indicators are not associated with any channel.

To associate an indicator with a channel, click an indicator with the right mouse button to bring up the configuration mode menu. Under **Associate** you will find a list of all configured channels, both hard and virtual. Simply select the channel you wish the indicator to be associated with from the list.

Only one channel can be associated to an indicator, but any number of indicators can be associated to a channel. Any indicators left without an associated channel will have their titles set to **Unassociated** and their appearance will be ghosted upon exiting configuration mode.

Note: The number of decimal places shown in a digital indicator is set within the associated channel definition.

5.2.1.3 Changing the displayed units

Upon first association with a channel, the indicator will display data in the declared units of that channel. However, indicators can convert the data and display those values in any other unit. This feature may prove useful for converting data acquired from a sensor that acquires in one system of measurement to another system of measurement. For example, one could report the pressure from a sensor calibrated for pounds per square inch in Pascal, or bar, without having to adjust the calibration multiplier.

To change the displayed units for an indicator, use the configuration mode shortcut menu and select the desired units from the **Display Units** item. The unit short form within the title of the indicator will then display the chosen units.

5.2.1.4 Peak recording

It is possible to set an indicator to remember the peak value, called Peak Recording. When a digital indicator is set to peak recording it will only show the peak value at all times. When a slide indicator is set to peak recording, a small needle is displayed above the scale that reports the peak value.

Titles for indicators with peak recording activated show a carat symbol, ^, for easy identification.

To activate peak recording for any indicator, right click the indicator and select **Show Peak** from the configuration mode menu. To disable peak recording, re-select the menu item.

During monitoring and acquisition it is sometimes desirable to reset the peak values of all indicators to clear their memory of previous data. This can be achieved at any time by selecting **View > Clear Peak Values** from the drop down menu.

5.2.1.5 Titles

Titles can be created to help identify regions of the panel and group indicators and slides. Titles are single lines of editable text.

To create a title, click the right mouse button within a region of free space on the panel to reveal the configuration mode menu. Select **New Title** from the menu. A new title will be created with the default content New Title.

To move a title from its current location, simply click and hold on the title with the left mouse button and move the title to the desired location. Release the mouse button to drop the title.

To edit the content, triple click the title to select all text and begin typing your new content to replace the existing text. Alternatively, single click within the title and use the delete key to erase the existing text, then enter your new content.

Note: There is a title count limit of 12.

5.2.1.6 Deleting indicators and titles

All indicators and titles can be deleted by clicking the object with the right mouse button and selecting Delete from the configuration mode menu.

To delete all indicators and titles from a panel, select **View » Configure » Clear Panel** to remove all objects from the current panel.

To delete all indicators and titles from all panels, select **View » Configure » Clear All Panels** to remove all objects from all panels.

5.2.2 Normal Panels 1 & 2

There are two Normal Panels in the C2000 software. These can be accessed through the menu items **View » Show Panel » Normal 1** (shortcut **F2**) and **View » Show Panel » Normal 2** (shortcut **F3**).

The Normal Panels provide the same features as the Super Panel, with the exception that the indicators and titles are smaller in size. Consequently, more indicators can be created within the Normal Panels than the Super Panel.

To enter edit mode, create, modify or delete indicators, slides and title, follow the instructions listed in the Super Panel section **5.2.1 Super Panel**.

Note: There is a total indicator and slide count limit of 48 for Normal Panels. There is also a title count limit of 12.

5.2.3 Graph Panel

The Graph Panel presents acquired data to the operator in a graphical plot. The graph is automatically configured to present the data from those channels associated with the indicators and slides of the Super Panel. A list of available channels is presented in the table to the right hand side of the panel, coupled with the channels' latest data value.

The Graph Panel can be accessed through the menu item **View » Show Panel » Graph Panel** (shortcut **F4**).

Unlike the Super Panel and Normal Panels, the configuration of the graph panel can be customised at any time without needing to enter Configuration Mode. For more details see Section **5.2.3.1 Configuring the Graph**.

Note: Changes to the Super Panel layout cause the Graph Panel to be automatically reconfigured to display those channels associated with the Super Panel indicators.

5.2.3.1 Configuring the Graph

The plots presented within the graph can be customised using the controls available within the Graph Panel.

Each channel available for plotting is tabulated alongside its latest data value and a checkbox. To disable a channel in the graph, select the checkbox beside the channel name in the table. The channel data will then be removed from the graph plot, and its entry removed from the legend.

To re-enable a channel in the graph, reselect the checkbox beside the channel name. The channel will be reinserted into the list of plotted channels.

By default, the graph plots data against a relative time axis. The origin of the x-axis is then 0, representing the point at which data acquisition began. Alternatively, the x-axis can show absolute time, or data from one of the available channels. To change the data used for the x-axis, simply select the **Horizontal Axis** listbox and select an entry from the list. When switching from a time to a channel for the horizontal axis, the selected channel will be deselected in the table. When switching back to a time axis, the channel will need to be reselected in the table for it to be plotted in the graph.

The colours, symbols and line styles used to draw each plot in the graph are represented within the legend. These can be changed by selecting the legend glyph with the left mouse button to show a shortcut menu of options for customising the properties of each plot.

The **Plot Live Data** checkbox can be used to stop and start the presentation of live data in the graph plot. Following a log process, this item is automatically unchecked to permit the plotting of the logged data in the graph plot. To recommence plotting of live data, simply recheck this item.

The auto-scaling option turns on and off automatic scale adjustments to the graph. With auto-scaling on, all axes will be adjusted to fit the data within the graph. Turn off auto-scaling to permit manual adjustment of the axes.

Note: Live data can only be plotted if Monitoring is active.

6. Data Logging

You can acquire data from the C2000 Midbox system with one of three acquisition techniques. Acquired data can then be saved to a C2000 data file and reports generated. The data can then also be loaded in to the Analysis panel tool for comparison with other previously acquired data.

The three acquisition methods available are:

- **Continuous** Acquisition at a constant sampling rate for a fixed period of time that begins immediately.
- **Profile** Acquisition at a constant sampling rate for a fixed period of time initiated by a trigger point. Log period can be before and/or after the trigger point.
- **Log on Keypress** Operator-controlled acquisition.

The C2000 logs data from all defined channels when performing a log process. The Graph Panel automatically plots those channels associated with indicators on the Super Panel. To graph any other channel, import the saved data file from within the Analysis panel. To plot all channels, see Section **9.4 Importing data files into a spreadsheet package**.

6.1 Performing a Log Process

To perform a data log process, select **start Log** from the banner (shortcut **F6**), or select **Data » Log Mode » Begin Logging** from the drop down menu; The Begin Logging window will appear. Populate the fields and select **start Logging** to begin the log process.

The top half of the Begin Logging window contains the user editable string fields that appear in the header of reports. Use these fields to record information related to the test.

The lower half of the Begin Logging window contains the log process settings:

- **Logging Mode** Continuous, Profile or Log On Keypress log mode
- **Sample Rate (Hz)** The sample rate of the acquisition (not available for Log On Keypress log mode)
- **Sample Points** The number of sample points for the current log (not available for Log On Keypress mode)
- **Sample Time (secs)** The log process time, equal to the division of Sample Points by Sample Rate (not available for Log On Keypress mode)
- **Pre-Trigger Sample Points** The number of sample points to keep prior to the trigger block (only available for Profile log mode)

- **Trigger Detection** The trigger mode, either rising edge or falling edge (only available for Profile log mode)
- **Channel** The trigger channel (only available for Profile log mode)
- **Threshold Value** The value at which triggering is set (only available for Profile log mode)
- **Filter** Filter type of the acquired data setting.
- **Filter Width** The width of the filter window (only available when Filter is set to Smoothing Window)

Set your desired log mode and log settings and select **Start Logging** to begin the log process.

Following a successful log process, the data will be downloaded from the C2000 Midbox and processed. The data is then presented in the Graph Panel graph and the Logging Complete window will appear. The **Filename prefix** field allows you to enter filename prefix characters that can be used as part of the automatically generated data file filename. Alternatively, select and replace the content of the suggested data file filename in the **Suggested filename** field. You are also given a second opportunity to edit the report header fields before saving.

Select **Save Data** to save the data to file, or **Cancel** to skip saving of the data.

*Note: If you select Cancel, you can still save the data at a later time by selecting **File » Save Test Data**. The data file filename entered in the **Suggested filename** field above will be used to save the data file.*

6.1.1 Continuous Log Mode

A continuous mode log process will acquire data from the C2000 Midbox at a constant sample rate until the desired number of sample points is acquired. To perform a Continuous mode log, set the **Logging Mode** to **Continuous**, set the **Sample Rate** and the desired number of **Sample Points** (or the desired **Sample Time (sec)**).

To abort a Continuous log process before the requested number of samples have been acquired, select **Abort Log** from the banner, select **Data » Log Mode » Stop Logging** from the drop down menu or use the keyboard shortcut **F6**. The sample points acquired so far will be downloaded from the C2000 Midbox.

6.1.2 Profile Log Mode

To set up a log process that listens for a particular value on a channel to act as a trigger, choose **Profile** from the **Logging Mode** list. This will reveal the Trigger settings. Choose the channel that will act as the trigger channel from the **channel** list, and select a trigger mode from the **Trigger Detection** list. A trigger mode of **Rising Edge** will activate the trigger when the channel value rises above the threshold value. Conversely, a **Falling Edge** will activate the trigger when the channel value falls below the threshold value. Enter the threshold value into the **Threshold value** field.

Finally, if a number of sample points prior to the trigger point are required, enter a value into the **Pre-Trigger Sample Points** field. This field must be smaller than the **Sample Points** field. For example, a Pre-Trigger Sample Points count of 500 with a Sample Points count of 1000 would return a data log of 1000 sample points, with 500 samples acquired before the trigger point and 500 samples following the trigger point.

To abort a Profile log process, select **Abort Log** from the banner, select **Data » Log Mode » Stop Logging** from the drop down menu or use the keyboard shortcut **F6**.

Note: Aborting a Profile log will provide no data.

6.1.3 Log On Keypress Log Mode

To begin a Log On Keypress log process, set the **Logging Mode** to **On Key Press**. For a Log On Keypress log mode the sample rate, count and triggering options are not applicable. Data points are logged individually each time the **Spacebar** is depressed. To begin logging, select **Start Logging**.

Live data will be presented in the four panels of the C2000 software. You can quickly switch panels using the **F1** to **F4** shortcut keys. To take a single sample, press the **Spacebar**. A pop up will indicate that a single block of data has been recorded. Continue taking samples with the **Spacebar**.

Note: The Log On Keypress logging method logs to file the data as it appears on the panels. Therefore, any Live Data Smoothing options that influence the live data also affect the logged data. Live Data Smoothing does not influence data captured through a Continuous or Profile logging method.

To review the data so far acquired within a Log On Keypress acquisition, press the **Enter** key. This will switch the Super Panel from Live mode to Review mode. In Review mode the recorded data can be viewed in the Super Panel indicators using the **Up Arrow** and **Down Arrow** keys. The Logging information banner will report the block number currently under review. New acquisitions can still be performed with the **Spacebar** in Review mode. To return to Live mode, press the **Enter** key.

To terminate a Log On Keypress log, either press the **Escape** key, select **Abort Log** from the banner, select **Data » Log Mode » Stop Logging** from the drop down menu or use the keyboard shortcut **F6**.

6.2 Reviewing Acquired Data

Following a successful data acquisition process, the data is presented in the Graph Panel graph. From here the data can be manipulated in a number of ways to customise the view.

Using the graph tools located toward the upper left of the Graph panel, one can zoom and pan the data in a variety of methods. Channels can be activated and deactivated using the table toward the lower right. The choice of horizontal axis data can be switched from time to any of the logged channels using the **Horizontal Axis** drop down listbox, and the styles used for plotting each channel can be altered from the legend.

Please refer to section **5.2.3 Graph Panel** for more details on configuring the Graph panel.

To review the acquired data alongside other data from a previous log process, please refer to Section **8 Analysis Tools**.

*Note: To inspect the data in a tabular format, please refer to Section 7 **Report Generation**.*

Note: The Graph Panel graph will only present data for the associated indicators on the Super Panel, however the data test file contains data for all defined channels. To see the logged data for channels not associated with any Super Panel indicators, import the data test file into the Analysis Panel.

7. Report Generation

The C2000 software can generate a Certificate of Test report of your test data. To create a report there must be logged data available, such as directly following a log process or loading of a data file.

To generate a report, select **Report** from the banner (shortcut key **F7**). The C2000 software will present the Report Generation panel.

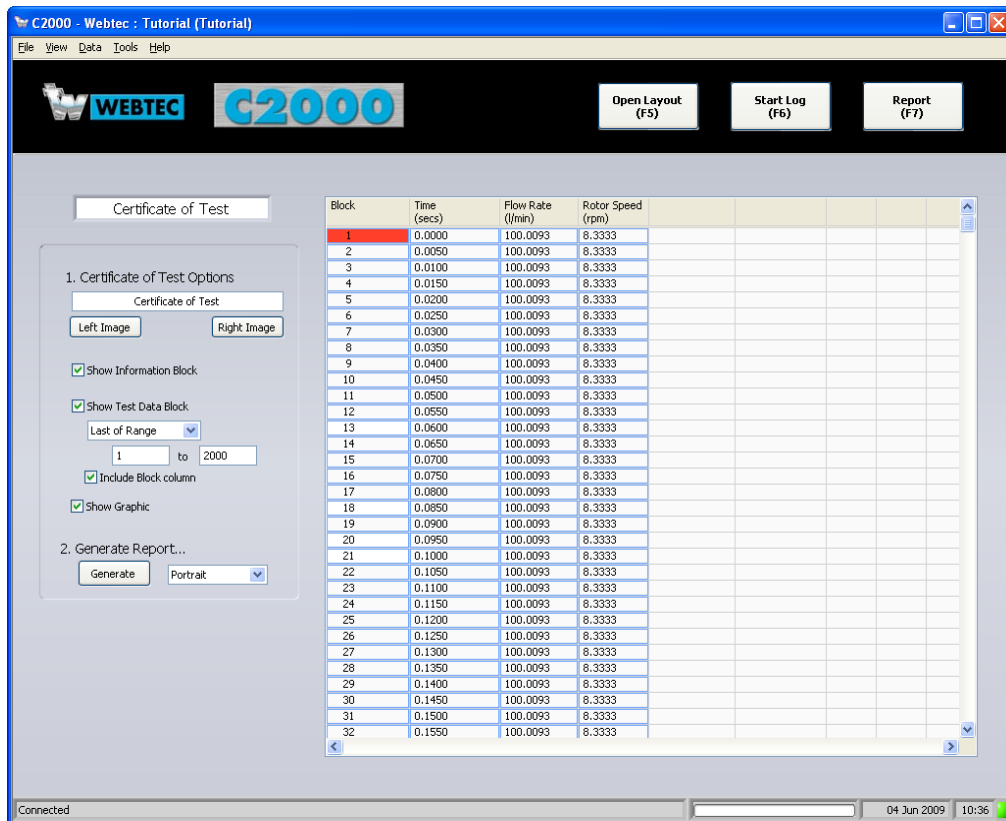

Figure 7.1 The Report Generation panel

The report panel contains a number of options, as well as a tabular representation of the logged data. For Certificate of Test reports, the report type information field will show **Certificate of Test**.

The C2000 can also generate snapshot reports. Snapshot reports contain only a snapshot image of your current view. For Snapshot reports, the report type field will show **Snapshot**. For more information on Snapshot reports, see Section 7.2 **Snapshot Report**.

Reports can also be produced from the Analysis panel (see Section 8 **Analysis Tools**). For Analysis reports, the report type field will show **Analysis**. For more information on Analysis reports, see Section 7.3 **Analysis Report**.

7.1 Certificate of Test Report

To generate a Certificate of Test report, select **Report** from the banner (shortcut key **F7**). The C2000 software will present the Report Generation panel.

For a Certificate of Test report, select from the Certificate of Test Options to customise the report appearance.

7.1.1 Customising a Certificate of Test Report

The Certificate of Test Options under the Report Generation panel provide the following settings:

- Title Text The title text for the Certificate of Test report, default **Certificate of Test**.
- Left Image Select to change the Image that appears in the left hand box of the report header.
- Right Image Select to change the Image that appears in the right hand box of the report header.
- Show Information Block Select to the show the custom text fields block of the Certificate of Test report.
- Show Test Data Block Select to include the table of data in the Certificate of Test report.
- Selected Data listbox When including the table of data in the report, select from Selected Data, Last of Range or First of Range. Note that choosing Selected Data when all data is selected can result in a long table of data spanning numerous pages.
- Range fields (0 to 999) The selected range of table data
- Show Graphic Select to include an image of the Graph Panel in the report. The Graph Panel graph time axis range will be adjusted to show only the Range fields selected range.

To generate the report, choose either **Portrait** or **Landscape** orientation from the listbox under Generate Report... and select **Generate**.

The Graph Panel graph will be adjusted to match the selected range of data, and an Adobe PDF format report will be generated and displayed in a separate preview window.

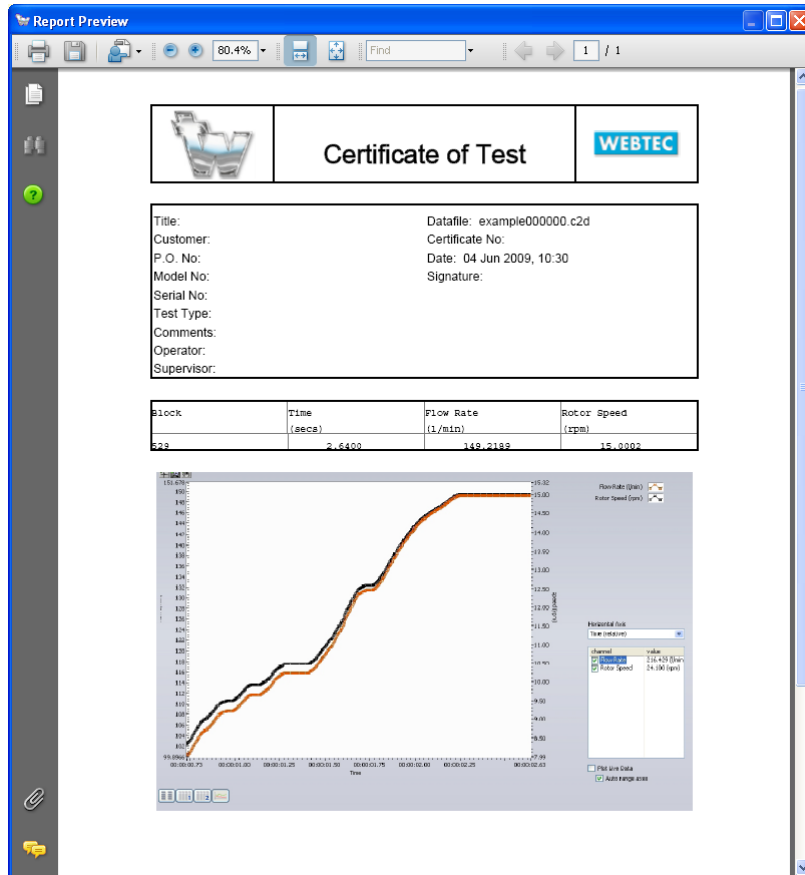

Figure 7.2 An example Certificate of Test Report shown in the Report Preview window

7.2 Snapshot Report

A Snapshot report is a very simple report that places a quick snapshot of the current panel view into a basic PDF report with a simple header.

To achieve a Snapshot report, select **View » Snapshot Report** from the drop down menu. A Snapshot report can be created from any C2000 panel.

The Report Preview window will show the basic report. The Print and Save tools also apply to Snapshot reports, allowing the quick creation, distribution and printing of basic reports.

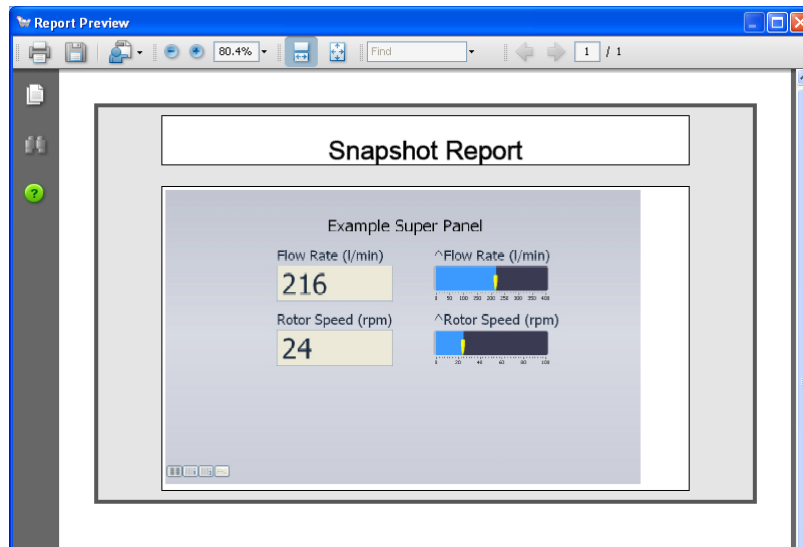

Figure 7.3 Example Snapshot Report for the Super Panel

7.3 Analysis Report

An Analysis report can be produced by selecting the Report button on the Analysis panel. Data from the Analysis graph will be copied into the report table for review.

An Analysis report is similar to a Certificate of Test report. The information block data is drawn from the first of the two data files imported. You can use the Certificate of Test Options to modify the appearance of the report. Please see Section **7.1.1 Customising a Certificate of Test Report** for more details on customising the appearance of reports.

Note: Changing the range of the data in the report data table will only affect the actual report table and not adjust the Analysis panel graph scale.

7.4 Printing and Saving a Report

A report can be printed from the Report Preview window. The Report Preview window utilises the Adobe Reader plug-in and includes the standard Adobe Reader tools.

To Print the PDF report, select the **Print** icon from the Adobe Reader icon bar (shortcut key **Ctrl+P**). A standard print dialogue box is shown. Make any changes to the Print settings and select **OK** (shortcut **Enter**).

To Save the PDF report, select the **Save** icon from the Adobe Reader icon bar (shortcut key **Ctrl+S**). A standard file dialogue window is shown. Choose a filename and select **Save** (shortcut **Enter**) to save a copy of the report.

Note: Certificate of Test reports, Snapshot reports and Analysis report can all be saved and printed from the Report Preview window.

7.5 Using Different Images in Reports

Every time a new layout is created through the **Layout Manager** the C2000 program copies `reportrightimage.jpg` and `reportleftimage.jpg` from the C2000 **Configuration folder** under `c:\Program Files\C2000` (see figure 7.4) in to the newly created **Projects file**. If these two image files are not present in the C2000 **Configuration folder** (figure 7.4) an error will occur when new layouts are created.

Where alternative images are used they can be of any size as the C2000 program resizes them appropriately for the **Report form**.

To use different images for reports two approaches can be taken:

1. **Permanently replace the default images:**

Replace the `reportrightimage.jpg` and `reportleftimage.jpg` images in **Program Files>>C2000>>Configuration** with the required files. Ensure the file names are the same as those they are replacing!

Every time a new layout is created the new left and right images will be copied to the new project file and used in report generation by default.

2. **Use different images for different layouts:**

Save the required images in the respective **projects** folder (see figure 7.5 for an example). Ensure you have the appropriate layout loaded, navigate to the report generation window and click the right image button and select the required image from the list. Repeat for the left image.

Every time this layout is loaded the new images (project specific) will be used in report generation. NB. The new images are resized and renamed `reportrightimage.jpg` and `reportleftimage.jpg` within the specific folder

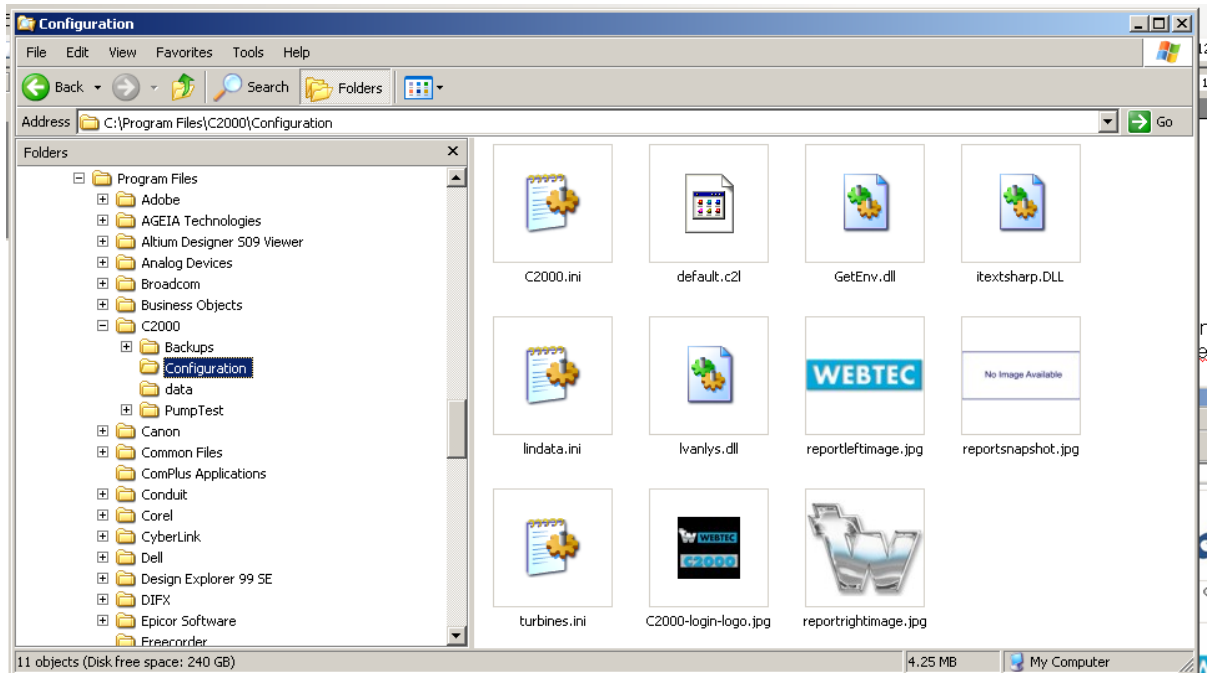

Figure 7.4. Location of master left and right images.

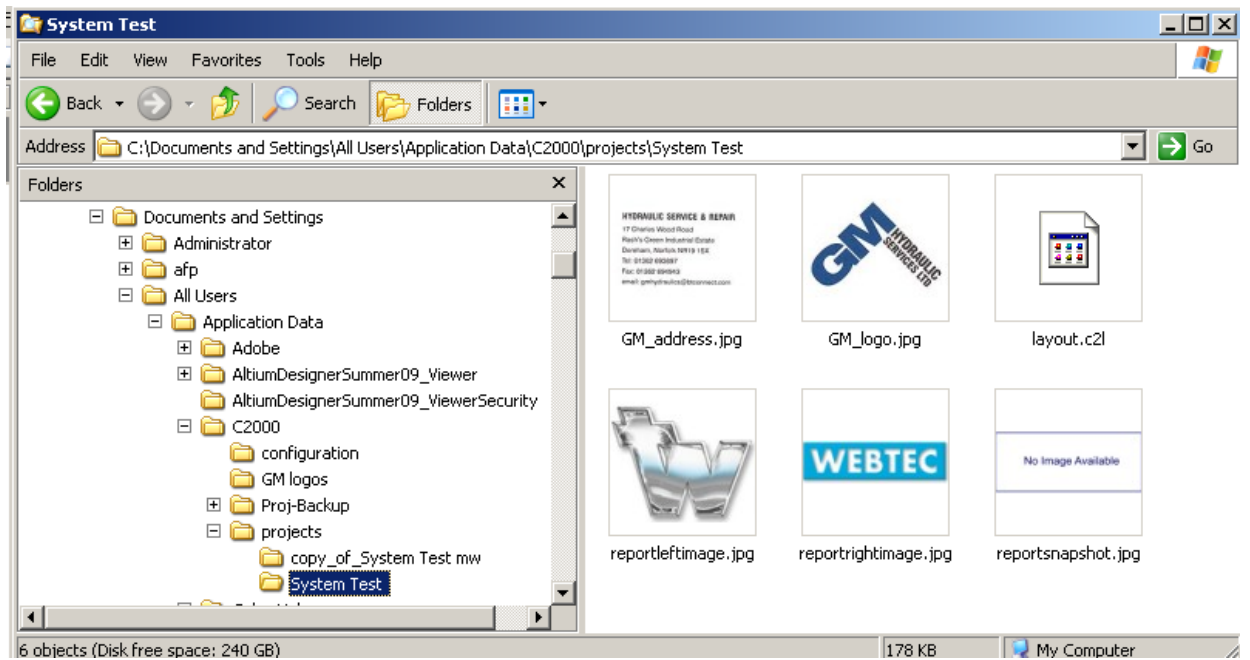

Figure 7.5. Location of user left and right images.

8. Analysis Tools

The Analysis tools panel allows for the comparison of two test data files. A selected set of channel data can be imported and simultaneously displayed in one graph. From here, all acquired data within a saved test data file can be accessed for analysis.

To access the Analysis tools, select **Tools » Analysis** from the drop down menu. The Analysis Panel will be displayed, containing a graphical display similar to that of the Graph Panel and a selection of tools for importing and exporting data.



Figure 9.1 Example Analysis panel

8.1 Importing Data into Analysis

Select **Import** from the Analysis Panel. The Analysis Data window will appear. In this window use the Browse buttons to select the two test data files to be imported and compared in the graph. The Available Channels tables will populate with the data contained within the selected data files. Select the checkbox beside those channels that you wish to have imported.

Note: C2000 log files contain data for all defined channels. Therefore you can select from your entire defined channel list when importing a data test file.

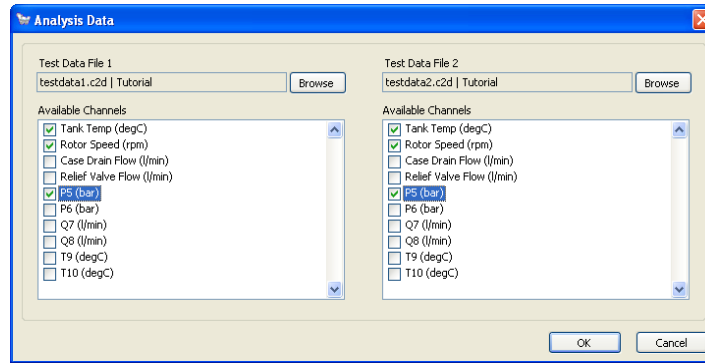

Figure 9.2 Example Import Analysis Data window

To load the selected channel data choose **OK**, otherwise choose **Cancel** to abort the import process.

The selected channels will be loaded from the test data files and combined in the Analysis Panel graph. As with the Graph Panel graph, appropriate y-axes will be created for the channel data. Within the legend, the test data filename will be appended to the channel title to aid identification.

Note: The combined channel title and data filename text used in the legends is truncated to a maximum of 23 characters.

8.2 Customising the Analysis Graph

The Analysis Panel graph responds in the same manner to the Graph Panel graph. Therefore, please see Section 5.2.3.1 **Configuring the Graph** for details on customising the graphical display.

8.3 Analysis Report

To generate a report of the Analysis panel data, select the **Report** button in the lower right corner of the Analysis panel. The Report panel will be shown populated with the data contained within the Analysis panel graph. See Section 7.3 **Analysis Report** for more details on generating an Analysis report.

9. Importing and Exporting Files

The C2000 permits export of acquired data files to other formats. This may be useful for importing the data into other packages, such as spreadsheet packages, for further data analysis.

9.1 Exporting a data file

To export a data file, first either acquire new data or load an existing data file into the C2000. Then, select **Save As Test Data** from the File menu, and choose a destination filename for the file. Ensure you use **csv** (comma separated value) as the file extension to produce an ascii formatted data file. The **csv** format will ensure the data exists within the file in a format easily interpretable by common spreadsheet packages such as Microsoft Excel.

Note: C2000 data files contains logged data for all defined channels. Exporting a data file to a third party spreadsheet package will allow for graphing of all logged channels.

9.2 Exporting an Analysis file

To export an analysis file in a comma separated value (csv) file format, first navigate to the Analysis panel (select **Tools » Analysis** from the drop –down menu).

Either **Import** new data to the analysis graph or **Load** an existing analysis file. Then select **Save** from the Analysis panel, and choose a destination filename for the file. Ensure you select **csv** (comma separated value) as the file extension to produce an ascii formatted analysis file. The **csv** format will ensure the data exists within the file in a format easily interpretable by common spreadsheet packages such as Microsoft Excel.

9.3 Importing data files into the C2000

ASCII formatted data and analysis files can be re-imported into the C2000 software. To load an ASCII test data file, select **File » Import** from the drop down menu. Navigate to the **csv** file and select **Import**. The data will be imported from the file as a standard data or analysis file.

Note: The C2000 software appends checksum characters into all file formats to effectively manage data integrity. ASCII formatted data files with edited content will be considered of unknown integrity and consequently may not be successfully imported.

9.4 Importing data files into a spreadsheet package

9.4.1 Importing a CSV formatted data file

To locate the data within the ascii formatted data file, you will need to skip beyond the first 289 lines of the data file. These initial blocks contain the layout and channel definitions. Follow the instructions provided with your spreadsheet package for importing a **csv** formatted data file, and jump to line 290.

Line 290 represents the channel labels, line 291 contains the units for each channel and the acquired data begins at line 292.

Note: A checksum character is included in the last line of the file. Therefore, remember to exclude the last line when importing data from an ascii formatted data file.

9.4.2 Importing a CSV formatted analysis file

The data is stored differently within an ascii formatted analysis file to help differentiate between the two original source files. No layout information is included, only the channel definitions. Follow the instructions provided with your spreadsheet package for importing a **csv** formatted data file, and jump to line 37 of the analysis file.

The two original source data files are handled sequentially, with definitions for the first data file appearing first. The first 36 lines contain the channel definition data. Line 37 contains the channel labels, line 38 contains the units for each channel and the acquired data begins at line 39.

The definitions for the second source file follow the data of the first source file. Therefore, for data containing 500 blocks, the second definition will begin at line 540. This again begins with the channel definitions for the second source file, followed by the channel labels, the channel units and finally the acquired data.

Note: A checksum character is included in the last line of the file. Therefore, remember to exclude the last line when importing data from an ascii formatted analysis file.

10. Troubleshooting

10.1 Hardware connection

The C2000 software communicates with the C2000 Midbox hardware through your Ethernet network connection. In the event that the hardware cannot be detected:

- Ensure the Midbox is powered and has had sufficient time to initialise (approximately 30 seconds).
- Check the system network connectivity. Use the Network Connections tools within Control Panel to determine connectivity to the Midbox.
- Use **Tools » Connect** to attempt to re-establish a connection with the Midbox. If this option is not available, first select **Tools » Disconnect** then retry.
- Repower the Midbox: Switch off the power to the Midbox cabinet for a full 10 seconds, then switch on the power. Wait 30 second for the system to initialise before attempting to reconnect. If the cabinet is remotely sited, function takes approximately 1 minute to complete.

10.2 Report preview

When generating reports with a lot of data included in the Test Data Block, it can take a significant amount of processing time to compile the data table. To avoid these circumstances, reduce the data selection included in the data by choosing either **First** or **Last of Selection** under **Show Test Data Block** within the report panel **Certificate of Test Options**.

The reports are generated in Adobe PDF format. The C2000 software uses the Adobe Reader plug-in to display reports in the Report Preview window. If the Report Preview window appears blank, ensure that Adobe Reader V8.0, or greater, is installed on the PC.

Note: Adobe Reader can be downloaded and installed for free from the following Adobe website: <http://get.adobe.com/reader>

10.3 Navigating the menus with the keyboard

The C2000 software can mostly be navigated without the use of a mouse. All user panels and menu items can be selected through either keyboard shortcut combinations or by selecting the **TAB** key to move the focus box to the desired item and pressing **Spacebar** to select.

Functions which necessitate use of a mouse include panel configuration, where the click and drag capabilities allow movement of indicators and labels, and right-click shortcut menus are required.

10.3.1 Defined keyboard shortcuts

- **Ctrl + C** Open the Channel Configuration window

- Ctrl + E Enter / Exit Panel Configuration mode
- Ctrl + H Open the Help window
- Ctrl + L Open the Layout Manager window
- Ctrl + M Enable / Disable Live Data Monitoring
- Ctrl + S Save the existing layout
- Ctrl + Shift + S Save a copy of the open layout
- F1 – F4 Switch between the Super Panel, Normal Panel 1, Normal Panel 2 and the Graph Panel
- F5 Open an existing layout (similar to Ctrl + O)
- F6 Begin a new data log process
- F7 Generate a Certificate of Test report
- Alt + F4 Will exit the C2000 software

10.3.2 Specialised Keyboard Shortcuts

- Escape key During a Log On Keypress process, will end the log process
- Spacebar During a Log On Keypress process, will acquire one block of data
- Enter During a Log On Keypress process, will enter / exit review mode
- Up Arrow In Review mode of a Log On Keypress process, will move to the next block for review
- Down Arrow In Review mode of a Log On Keypress process, will move to the previous block for review



Nuffield Road, St Ives, Cambridgeshire, PE27 3LZ, UK
Tel: +44(0)1480 397400 Fax: +44(0)1480 466555

E-mail: sales@webtec.co.uk
Internet: <http://www.webtecproducts.com>



Certificate No.8242