



**WEBTEC**

**WEBTEC PRODUCTS LIMITED**

## ***LT Series Flow Meters User Manual***

**LT5, LT10 and LT16**

**LT50, LT125, LT250, LT400, LT500, LT750, LT750HP  
LTE15, LTE30, LTE50, LTE125, LTE250, LTE400, LTE1000  
LT250R, LT400R, LT750R, LT750HPR**



**[www.webtec.co.uk](http://www.webtec.co.uk)**

**LT Series Flow Meters User Manual**



## Introduction

Webster flow meters are designed for intermittent or continuous testing of hydraulic systems on test stands, machine tools, and many other static or mobile machines. The compact and easy-to-install turbines have an accuracy of  $\pm 1\%$  of full scale deflection (FSD) over a 10 to 1 (normal) range, and  $\pm 2\%$  FSD over a 25 to 1 (extended) range. Accuracy is also dependent on the type of readout used. Accuracy better than  $\pm 1\%$  of indicated reading can be obtained, please consult sales office.

All the turbine flow meters are designed to withstand high pressures, of the order of 350 bar or more, whilst the turbine blade has been designed to minimise the effects of viscosity.

A magnetic reluctance transducer measures the speed of the turbine; each time a blade passes the transducer an electrical pulse is generated. The transducer requires no external power supply and incorporates a thermistor to measure fluid temperature. An optional powered transducer is available for extended low range capability (without thermistor). Additional temperature and pressure sensors can be fitted to some of the flow meters. See separate manual for more information.

The range of Webster flow meters can be divided into four families:

Positive displacement	LT5, LT10 and LT16
Turbine	LT50, LT125, LT250, LT400, LT500, LT750, LT750HP
Turbine (with anti-swirl)	LTE30, LTE50, LTE125, LTE250, LTE400
Turbine with loading valve	LT250R, LT400R, LT750R, LT750HPR

Details of the flow meter characteristics and installation instructions are laid out below according to family type.

## Gear Type Positive Displacement Flow meters (LT5, LT10 and LT16)

Pin No.	Function
1 & 2	Transducer
3 & 4	Thermistor
5	Ground

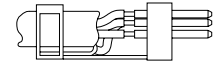
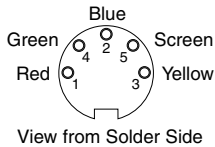

Solder screen and link wire to cable clamp as shown

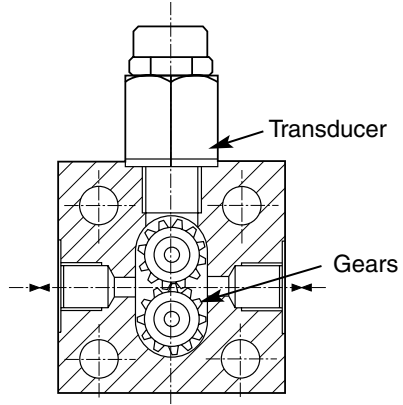

The LT positive displacement flow blocks LT5, LT10 and LT16 offer an overall flow range of 0.1 lpm to 16 lpm, do not require any minimum length of straight tube and can be used to measure flow in both directions (calibrated in one direction only).

**Flow Block:** Solid high tensile aluminium alloy.

**Turbine:** The two 14 tooth gears rotate on low friction stainless steel ball bearings.

**Seals:** Viton "A", compatible with mineral oil, fuels, water glycol and water oil (EPDM seals for use with phosphate-ester available).

### Flow Range

Model	Normal Flow Range (Extended)		Nominal Meter K Factor (pulses per unit flow)		Max. Pressure bar
	lpm	gpm (US)	per litre	per gall (US)	
LT5	0.1 - 5	0.03 - 1.3	7500	28390	420
LT10	0.2 - 10	0.05 - 2.6	6300	23850	200
LT16	0.2 - 15 (16)	0.05 - 4 (4.2)	6200	19700	200

### Installation recommendations

When using this type of flow block to measure low pressure systems, such as case drain leakage, it is recommended that a relief valve or check valve is fitted to protect against excessive pressure caused by surge flows. We also recommend that a filter of minimum 15 micron absolute be fitted up-stream of positive displacement flow blocks.

## Six Blade Turbine Flow Meters

### (LT50, LT125, LT250, LT400, LT500, LT750 and LT750HP)

Pin No.	Function
1 & 2	Transducer
3 & 4	Thermistor
5	Ground

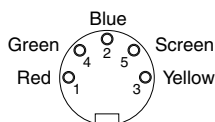

View from Solder Side

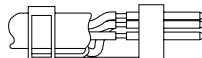

Solder screen and link wire to cable clamp as shown

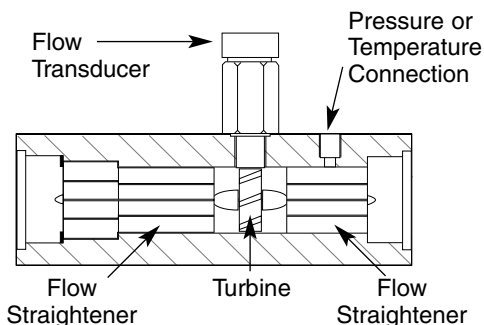

LT type turbine flow meters are available in six sizes giving an overall extended range from 2 to 800 lpm with a maximum pressure rating of 420 bar at the lower flow rates and 350 bar at higher flow rates (750HP - 480 bar). The LT turbines have a built in flow straightener so the recommended minimum length of straight tube, equal to 10 diameters, can be reduced to 8 diameters where space is limited. Inlet connections should always be of adequate size to prevent venturi or constriction effects. The Webster range of flow meters can be used to measure flow in either direction provided that straight tubing is used in both connections. Micron particle contamination has little effect.

**Turbine Block and straighteners:** Solid high tensile aluminium alloy

**Turbine:** The six bladed turbine rotates on a stainless steel bearing and shaft

**Seals:** Viton "A", compatible with mineral oil, fuels, water glycol and water oil (EPDM seals for use with phosphate-ester available).

### Flow Range

Model	Normal Flow range		Extended Flow Range		Nominal Meter K Factor <i>(pulses per unit flow)</i>		Max. Pressure bar
	lpm	gpm (US)	lpm	gpm (US)	per litre	per gall (US)	
LT50	8 - 50	2 - 13	2 - 60	0.5 - 16	630	2385	420
LT125	12 - 120	3 - 32	5 - 150	1 - 40	630	2385	420
LT250	20 - 220	5 - 58	10 - 300	2.5 - 80	120	454	420
LT400	30 - 300	8 - 80	10 - 400	2.5 - 106	120	454	420
LT500	45 - 450	12 - 120	20 - 600	5 - 160	88	333	350
LT750	50 - 700	13 - 185	30 - 800	8 - 211	57	216	350
LT750HP	50 - 700	13 - 185	30 - 800	8 - 211	57	216	480

## Flow Range

The following flow meters are specially calibrated for the U.S. market only.

Model	Normal Flow range		Extended Flow Range		Nominal Meter K Factor <i>(pulses per unit flow)</i>		Max. Pressure
	lpm	gpm (US)	lpm	gpm (US)	per litre	per gall (US)	bar
LT750	20 - 650	5 - 172	20 - 650	5 - 172	57	216	350
LT760	30 - 800	8 - 211	30 - 800	8 - 211	57	216	350

## Installation and operation

Use copper washers or bonded sealing washers to seal the flow block inlet and outlet connections. Blocks can be supplied with BSPF, JIC, NPT, or SAE flange adapters to connect to hoses or steel tube. If hydraulic valves are used to switch the flow to each block, they should be positioned 15 - 20 diameters up stream of the flow block to avoid turbulence. The flow blocks can be mounted in the high or low pressure lines but care should be taken to ensure that the flow block is installed in a position which is not subjected to excessive pulsation as this can cause incorrect readings. For heavy-duty applications, for example installation close to a piston pump, consult the Webtec Products sales office.

## Six-blade turbine flow meters with anti-swirl discs (LTE15, LTE30, LTE50, LTE125, LTE250 and LTE400, LTE1000)

Pin No.	Function
1 & 2	Transducer
3 & 4	Thermistor
5	Ground

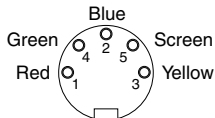

View from Solder Side

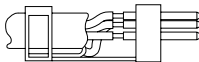

Solder screen and link wire  
to cable clamp as shown

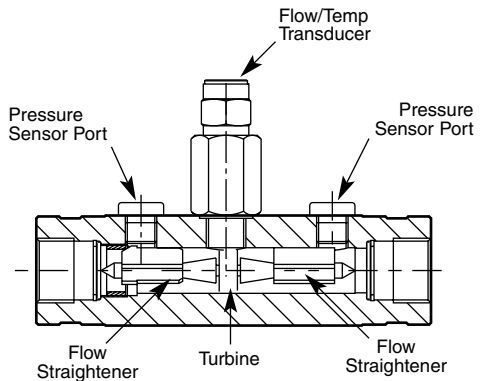

LTE type turbine flow meters are available in five sizes giving an overall extended range from 1 to 400 lpm with a maximum pressure rating of 420 bar throughout. LTE turbines incorporate specially designed swirl-reducing flow straighteners allowing inlet and outlet connections to be 90° bends. This makes the LTE range ideal for installation in compact systems where space is at a premium. Inlet connections should always be of adequate size to prevent venturi or constriction effects. The Webster range of flow meters can be used to measure flow in either direction. Micron particle contamination has little effect.

**Turbine Block and straighteners:** Solid high tensile aluminium alloy

**Turbine:**

The six bladed turbine rotates on a stainless steel bearing and shaft.

**Seals:**

Viton “A”, compatible with mineral oil, fuels, water glycol and water oil (EPDM seals for use with phosphate-ester available).

## Flow Range

Model	Normal Flow range		Extended Flow Range		Nominal Meter K Factor <i>(pulses per unit flow)</i>		Max. Pressure
	lpm	gpm (US)	lpm	gpm (US)	per litre	per gall (US)	
<b>LTE15*</b>	1 - 15	-	1 - 25	-	6000	-	420
<b>LTE30**</b>	4 - 30	1 - 8	1 - 50	0.3 - 13	630	2385	420
<b>LTE50</b>	8 - 50	2 - 13	2 - 60	0.5 - 16	630	2385	420
<b>LTE125</b>	12 - 120	3 - 32	5 - 150	1 - 40	630	2385	420
<b>LTE250</b>	20 - 250	5 - 66	10 - 300	2.6 - 80	146	553	420
<b>LTE400</b>	30 - 300	8 - 80	10 - 400	2.6 - 106	146	553	420
<b>LTE1000</b>	-	-	-	-	-	-	350

**LTE15\*** turbine flow meters do not contain anti-swirl discs, see installation details for LT series.

**LTE30\*\*** turbine flow meters obtain greater accuracy at lower flows by using a powered transducer. There is no temperature output from this transducer. Due to this being a sensitive device, it is recommended that it not be installed close to sources of electromagnetic interference (i.e. electric motors). The pin allocations for this transducer are as follows: Pins 1 & 2, ground; Pin 3, supply voltage 6 - 16 VDC at 6mA; Pin 4, signal out  $\pm 1V$ ; Pin 5, not connected (but if requested can be set for 5V supply voltage).

## Six blade turbine flow meters, with built-in loading valves (LT250R, LT400R, LT750R and LT750HPR)

Pin No.	Function
1 & 2	Transducer
3 & 4	Thermistor
5	Ground

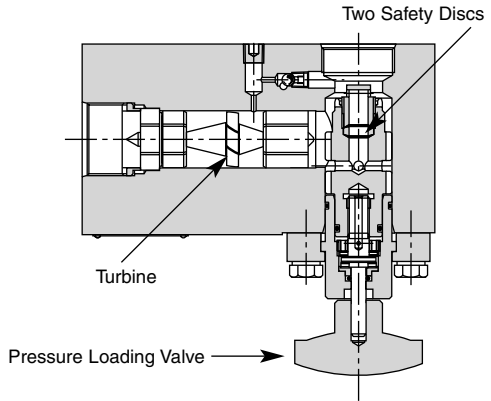
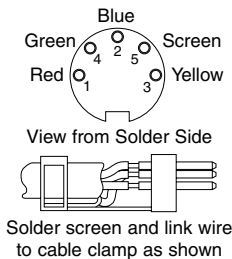

LTR type turbine flow meters are available in three sizes giving an overall extended range from 2 to 800 lpm with a maximum pressure rating of 420 bar at the lower flow rates and 350 bar at higher flow rates (750 HPR - 480 bar). The LTR turbines have an integral loading valve capable of giving progressive pressure loading in either flow direction. The loading valve contains replaceable safety discs, which relieve the pressure at approximately 7 bar (100 psi) over the maximum pressure, by-passing the oil internally. There is a built in flow straightener so the recommended minimum length of straight tube, equal to 10 diameters, can be reduced to 8 diameters where space is limited and on the loading valve end 90° bends are permitted. Inlet connections should always be of adequate size to prevent venturi or constriction effects. The Webster range of flow meters can be used to measure flow in either direction (lower accuracy is achieved in the reverse direction). Micron particle contamination has little effect.

**Turbine Block and straighteners:** Solid high tensile aluminium alloy

**Turbine:**

The six bladed turbine rotates on a stainless steel bearing and shaft.

**Seals:**

Viton "A", compatible with mineral oil, fuels, water glycol and water oil (EPDM seals for use with phosphate-ester available).

## Flow Range

Model	Normal Flow range		Extended Flow Range		Nominal Meter K Factor <i>(pulses per unit flow)</i>		Max. Pressure
	lpm	gpm (US)	lpm	gpm (US)	per litre	per gall (US)	bar
<b>LT250R</b>	20 - 220	5 - 58	10 - 300	2.6 - 80	120	454	420
<b>LT400R</b>	30 - 300	8 - 80	10 - 400	2.6 - 106	120	454	420
<b>LT750R</b>	50 - 700	13 - 185	30 - 800	8 - 211	57	216	350
<b>LT750HPR</b>	50 - 700	13 - 185	30 - 800	8 - 211	57	216	480

The following flow meters are specially calibrated for the U.S. market only.

Model	lpm	gpm (US)	lpm	gpm (US)	per litre	per gall (US)	bar
<b>LT500HPR</b>	20 - 500	5 - 132	20 - 500	5 - 132	88	333	480
<b>LT760R</b>	30 - 800	8 - 211	30 - 800	8 - 211	57	216	350

## Loading Valve and Safety Discs

Webster INTERPASS safety disc system

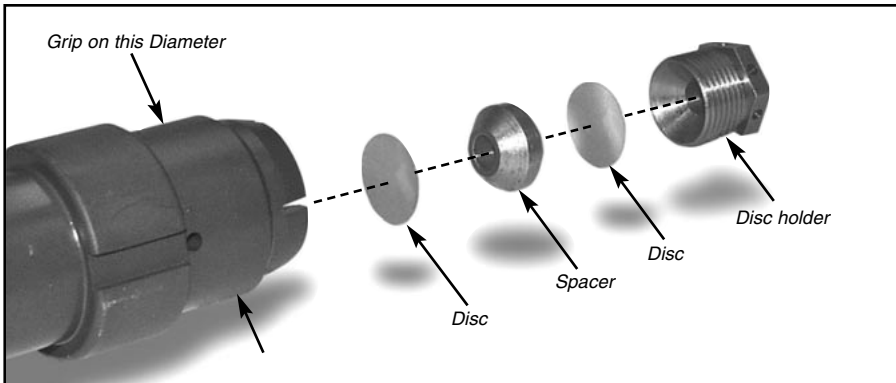

The loading valve is fitted with two safety discs that are designed to rupture internally at approximately 100 psi (7 bar) over the maximum pressure. When these discs fail, the loading valve becomes inoperative and the oils flows freely downstream. Spare discs are supplied with each valve and these can be quickly and easily replaced.

# Pressure Drop Chart

Hydraulic Oil Viscosity 28 Centistokes

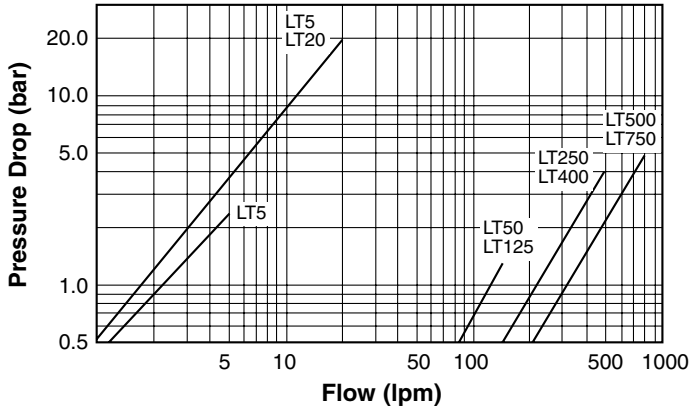

## Note

1 UK gallon = 4.546092 litres

1 US gallon = 3.785412 litres

## For Sales & Service contact:

Distributor

07/03

### USA & Canada

#### Webster Instruments

1290 E Waterford Avenue  
Milwaukee, WI 53235, USA.

Tel: 414-769-6400

Fax: 414-769-6591

### France

#### Webtec SARL

Route de Cantaing, 59267 Proville, France.

Tel: 03 27 82 94 56

Fax: 03 27 82 94 55

### Germany

#### Webster Messtechnik

An der Palmweide 55, 44227 Dortmund, Germany.

Tel: 02 31 97 59 747

Fax: 02 31 97 59 710



**Nuffield Road, St. Ives, Cambridgeshire, PE27 3LZ, UK**

**Tel: +44(0)1480 397 400 Fax: +44(0)1480 466 555**



**E-mail: [sales@webtec.co.uk](mailto:sales@webtec.co.uk)  
See us at: [www.webtec.co.uk](http://www.webtec.co.uk)**



LT-MA-ENG-0735.pdf

Designed and produced by the Marketing Dept. Webtec Products Ltd.